

### Seal housing

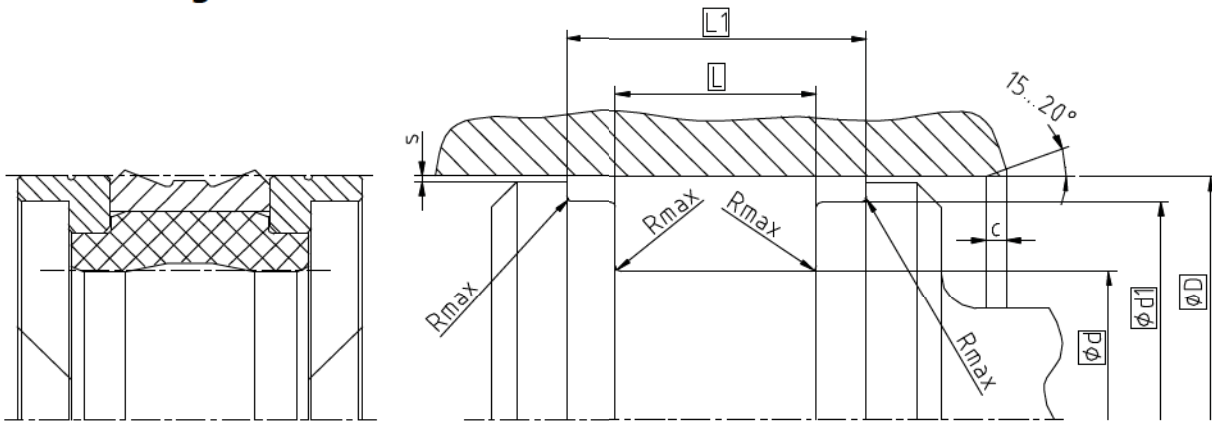

Surface roughness	Rtmax	Ra
Sliding Surface	≤ 2,5 μm	0,1...0,5 μm
Bottom of groove	≤ 6,3 μm	≤ 1,6 μm
Groove face	≤ 15 μm	≤ 3 μm

Ordering dimensions...□

Bearing area: 50...95% and a cutting depth of 0,5xRz based on Cref = 0%

### Standard dimensions

∅D H9	∅d h9	∅d1 h8	L +0,2	L1	Rmax	c	s*
≥ 20 ... < 50	D - 10	D - 3	12,5	20,5	0,4	4	0,35
≥ 50 ... < 80	D - 15	D - 4	20	28	0,4	5	0,52
≥ 80 ... < 150	D - 20	D - 5	25	36	0,4	6	0,65
≥ 150 ... < 400	D - 25	D - 6	32	46	0,4	8,5	0,78
≥ 400 ... < 600	D - 30	D - 8	36	50	0,4	10	1,00

\* Extrusion gap applies to a temperature of 70 °C, higher temperatures require lower values.

### Operating parameters

Sealing material	Energizer	Backup ring	Temperature	max. speed	max. pressure <sup>1</sup>
ECOPUR®	SKF ECORUBBER-1	SKF ECOTAL SKF ECOMID <sup>2</sup>	-30 °C...+100 °C	0,5 m/s	400 bar (40 MPa)
H-ECOPUR™			-20 °C...+100 °C		
S-ECOPUR™			SKF ECOSIL	-40 °C...+100 °C	
T-ECOPUR™	0,5 m/s				

The stated operation conditions represent general indications. It is recommended not to use all maximum values simultaneously. Surface speed limits apply only to the presence of adequate lubrication film.

<sup>1</sup> Pressure ratings depend on the size of the extrusion gap.

<sup>2</sup> ≤ ∅260mm: SKF ECOTAL ; > ∅260mm: SKF ECOMID

### Ordering example

K09-D, D=100mm, d=80mm, d1=95, L=25mm, L1=36mm, ECOPUR® / SKF ECORUBBER-1 / SKF ECOTAL

**Piston Seal K09-D 100 x 80/95 x 25/36 ECOPUR® / SKF ECORUBBER-1 / SKF ECOTAL**

Profile

D x d/d1 x L/L1

Sealing material / Energizer / Backup ring