

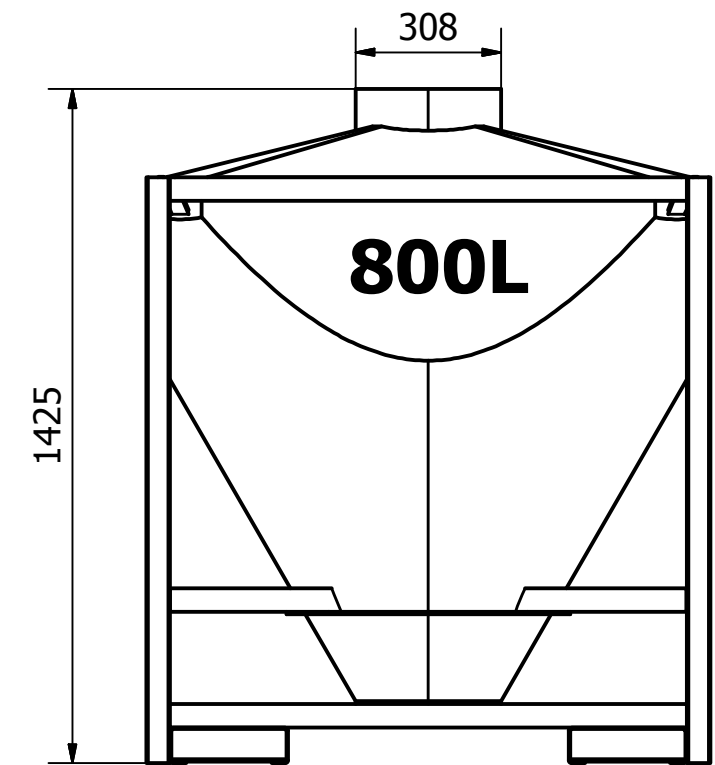

CAS ENTERPRISES STANDARD IBC RANGE

- FORKLIFT POCKETS CAN BE CHANGED TO SUIT YOUR REQUIREMENTS
- FRAMES GENERALLY HOT DIP GALVANISED
- INLET AND OUTLET Ø300 I/D

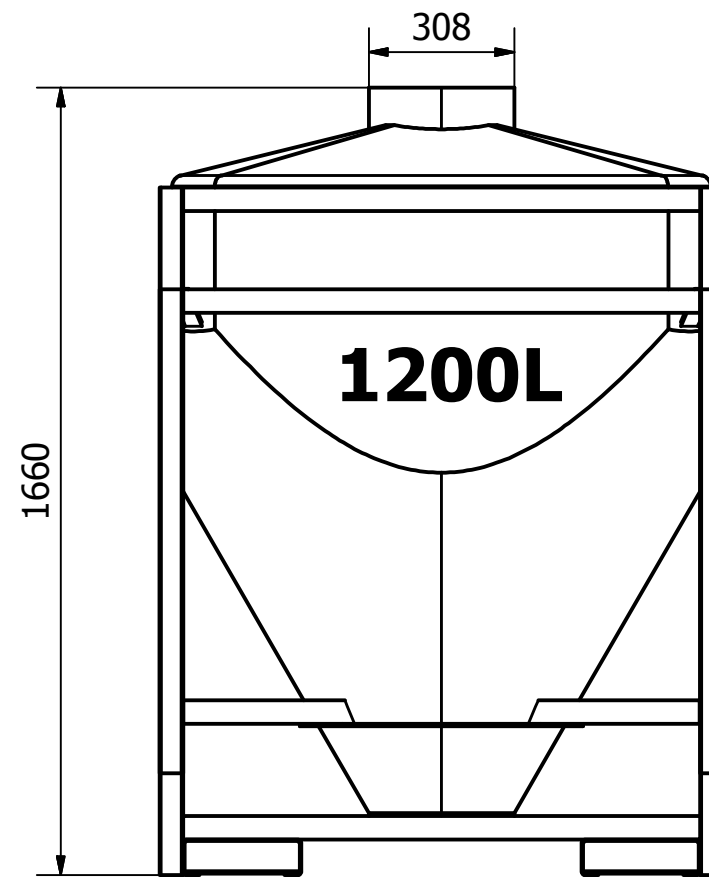
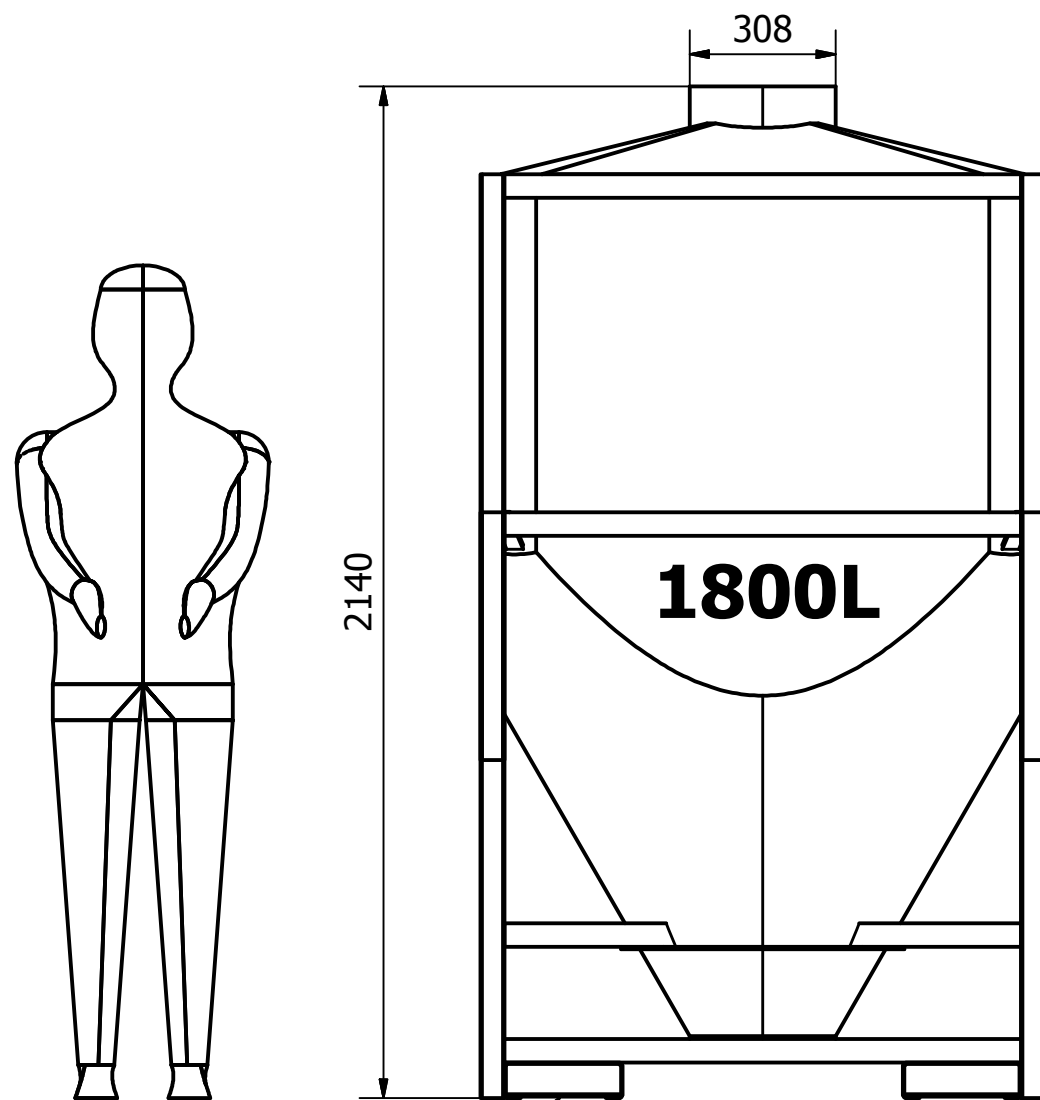
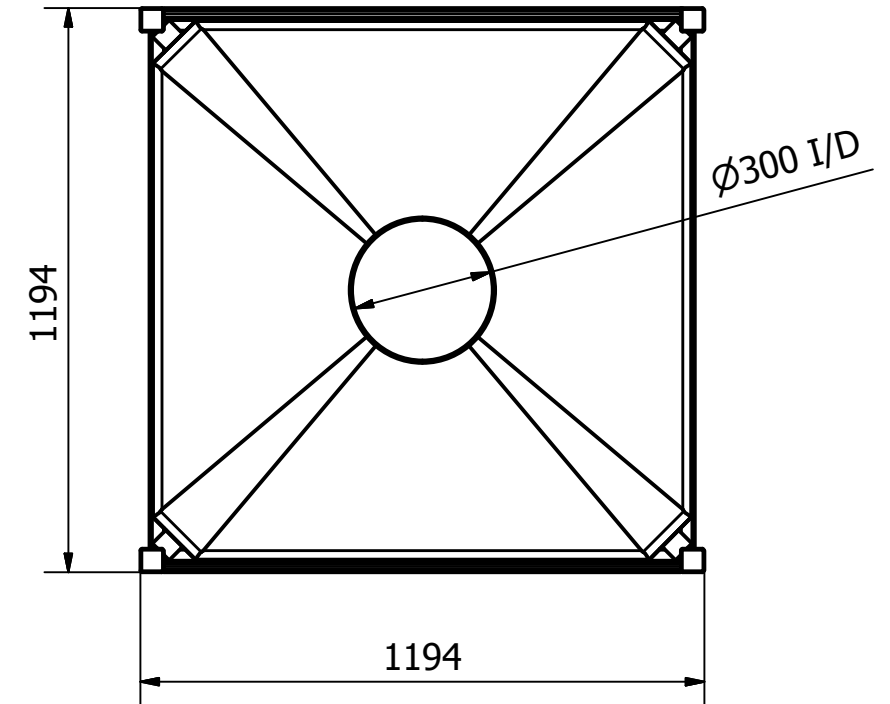

Fabrication & Machining Tolerances	Designed by CAS	Checked by	Approved by	Approved date	Drawn Date 26/08/2013
Fabrication: ± 1.00mm Machining: ± 0.05mm Surface Finish: 240 Grit Unless Noted Otherwise		PO Box 97-383 Manukau 2241 Ph: 09 263 9393 Fax: 09 263 9394 Email: cas@xtra.co.nz www.cas.co.nz		CAS ENTERPRISES	
		IBC RANGE	Revision 00	Sheet 1 / 1	