

Data/ Specification Sheet

MONARCH® Dry Chemical Automotive Paint Spray Booth Fire Suppression System



TM

- ▶ 1. Fixed temperature mechanical or thermal detectors
- 2. Electrical conduit protecting stainless steel cable
- 3. Model MCH Control Head
- 4. Pneumatic rigid pipe and/or flexible tubing
- 5. Model PCI-Series Agent Storage Cylinders
- 6. Fixed agent distribution piping
- 7. Extinguishing Agent Discharge Nozzles
- 8. Alarm Bell
- 9. Time Delay
- 10. Model RPS-M Remote Mechanical Pull Station

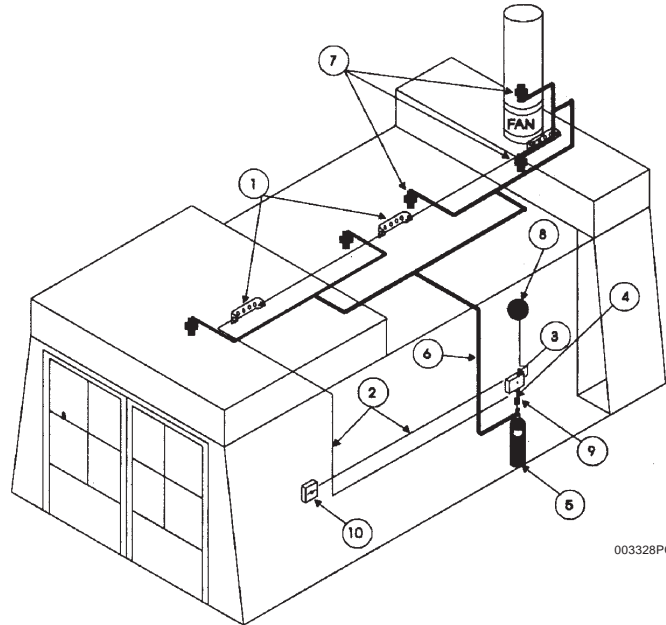

003328PC

General

- Paint spray booths/rooms are areas designed to confine or limit the escape of spray, vapor, and residue. A power ventilation system dedicated to these areas ensures the appropriate exhaust of residual material. Pyro-Chem's dry chemical extinguishing agents are appropriate for Class A, B, or C fires. A careful hazard survey should be conducted to properly define the type of fire to be extinguished. In addition to flammable/combustible liquids, the material composition of the object to be painted must be considered as well as resident material in the protected area.
- ▶ Total flooding fire extinguishing techniques as defined by NFPA 17 are utilized by Pyro-Chem's Monarch® fire suppression systems to protect the entire hazard which includes the work area, exhaust plenum area, pits, under floor's and exhaust ducts.

The National Fire Protection Association Standard No. 33 "Spray Application Using Flammable and Combustible Materials" and No. 17 "Dry Chemical Extinguishing Systems" are primary reference sources and provide guidelines for the proper application and design of Pyro-Chem's Monarch® Industrial Fire Suppression Systems in the specialized protection of paint spray booths and rooms. Underwriters Laboratories testing provides pre-engineered system application parameters allowing the flexibility to protect a variety of paint spray booth/room layouts to Underwriter's Standard UL 1254, effective September 1998, with confidence.

System Operation

Paint spray booth fire protection is a special application of Pyro-Chem's Monarch® Industrial Fire Suppression System. It provides a highly reliable response with the versatility of automatic or manual activation.

- A modular concept of protection is used. A nozzle, with a prescribed area of protection positioned according to pre-engineered placement parameters, protects a modular area of hazard. Sets of nozzles supplied by a dedicated cylinder containing dry chemical extinguishing agent and piped in an approved pattern consistent with the application coverage are utilized.
- ▶ Mechanical or electrical fixed temperature detectors are positioned strategically within the protected area to monitor ambient temperature and initiate an output should the rated temperature be exceeded. The detector input is "sensed" at the control head. The control head responds by discharging the system by pneumatically depressing the stored agent cylinder valve. The system is provided with a time delay device to allow for fan shut down before agent discharge. A manual means of activating the system is also provided.

Expanded capability is available to provide remote manual activation, auxiliary electrical outputs and/or audible alarms. This optional equipment will enhance the basic system functions and be applicable when designing custom configurations to suit a particular customer's needs and/or comply with local codes.



One Stanton Street
Marinette, WI 54143

May 10, 2004

Suggested Architect's Specifications

1. General

- 1.1 – The fire extinguishing system shall be the stored pressure dry chemical pre-engineered fixed nozzle type manufactured by Pyro-Chem. The system shall provide for the protection of the paint spray area(s) described in drawing _____. (Note drawing number and revision.)
- 1.2 – The system shall be capable of automatic and manual actuation. It shall be U.L. Listed and installed in conformance with National Fire Protection Association Standard No. 17, "Dry Chemical Extinguishing Systems" and No. 33, "Spray Application using Flammable and Combustible Materials," and comply with all local and/or state Codes and Standards.
- 1.3 – The system shall be designed for operation at ambient temperatures from 32°F to 120°F (0 °C to 49 °C).

2. Cylinder and Agent

- 2.1 – Agent. The system shall use Pyro-Chem monoammonium phosphate-based dry chemical agent.
- 2.2 – Cylinders. Steel cylinders manufactured, tested, and marked in accordance with DOT 4B 350 or DOT 4B 500 shall be used to store the extinguishing agent. Cylinder Models PCI-15ABC shall be used with extinguishing agent fill weight of 12.5 lbs. Cylinder Models PCI-17ABC shall be used with extinguishing agent fill weight of 17 lbs. Cylinder Models PCI-25sABC shall be used with extinguishing agent fill weight of 25 lbs. Cylinder Models PCI-35ABC shall be used with extinguishing agent fill weight of 35 lbs. Cylinder Models PCI-70ABC shall be used with extinguishing agent fill weight of 70 lbs. All models are charged with dry nitrogen to 350 psig at 70°F.
- 2.3 – Cylinder valve. A pressure sealed poppet-type valve having a brass body, stainless steel stem with rubber seat washer, fusible safety relief assembly, and pressure gage shall be used on all agent cylinders.
- 2.4 – Cylinder bracketing. Cylinders shall be mounted vertically. The cylinders shall be secured by use of a steel mounting bracket affixed to a rigid object capable of supporting the weight of the filled cylinder and the concussion of cylinder discharge.

3. Actuation Controls

- 3.1 – Control Head. The system control head shall include a Model MCH, NMCH or ECH-Series Control Head. The control head shall be mounted directly on the time delay in a Model MB-P2 control-head mounting bracket. The control head can actuate up to five centrally located agent cylinders. A carbon dioxide pilot cartridge that complies with MIL-C0601G shall be used as an integral component of the control head. Control head status shall be visually indicated by a SET/FIRED indicator.
- 3.2 – Time Delay. The system shall have a Model T-10 Time Delay to allow for fan shut down before agent discharge.
- 3.3 – Detection. The ambient temperature of the hazard area shall be monitored by fixed temperature mechanical or electrical thermal detectors. When the temperature of the hazard area exceeds the rating of any detector, the detector shall a) release tension in a cable connected to the control head, causing control head activation (for mechanical detectors), or b) close a normally open switch element within the detector, sending a signal to the control head which energizes a solenoid in the control

head, exercising the control head (for electrical detectors).

- 3.4 – Pneumatic actuation. For systems requiring more than five agent cylinders, the system shall have a PAC-Series Pneumatic Actuating Cylinder whose valve opens upon activation of the control head. The valve shall release nitrogen from the PAC cylinder into the pneumatic pipe and tubing network. This nitrogen shall depress a piston above the valve stem in each agent cylinder, opening each agent cylinder valve and releasing the pressurized agent.
- 3.5 – Manual actuation. The system shall have mechanical manual actuation capability requiring no electrical power. This is accomplished locally by twisting the handle on the cover of the MCH or ECH Control Head, or remotely by means of a Model RPS-M remote mechanical pull station.
- 3.6 – Auxiliary output. The system shall provide for the shut off of power to equipment within the hazard and to ventilation systems in the event of system actuation. This is accomplished by means of dry contacts on a Model MS-SPDT or MS-DPDT miniature switch installed in the control head. The miniature switch may also be used for auxiliary functions such as audible alarms or alarm signaling.
- 3.7 – Supervision. A Model SM Series Solenoid Monitor shall be used to supervise the integrity of all electrical actuation circuits, whether automatic or manual.
- 3.8 – Manual electrical actuation (optional). The system shall have electrical manual actuation capability. This is accomplished by the use of a Model RPS-E2 Remote Electrical Pull Station installed in the automatic detection circuit.

4. Distribution Nozzles

- 4.1 – Nozzles. The system shall utilize Pyro-Chem discharge nozzles to distribute agent throughout the hazard area. The model, quantity, location, and orientation of nozzles shall be in accordance with Pyro-Chem Industrial Fire Suppression System Technical Manual, Part No. 551229.
- 4.2 – Nozzle covers. All nozzles shall be installed with nozzle covers to prevent foreign matter from clogging the discharge nozzles.

5. Pipe and Fittings

- 5.1 – Pipe. All pipe shall be Schedule 40 black, galvanized, chrome plated or stainless steel pipe in compliance with NFPA 17. All pipe ends shall be thoroughly reamed after cutting, and all oil, chips, and debris shall be removed prior to nozzle installation.
- 5.2 – Fittings. Standard weight malleable, galvanized, chrome plated or stainless steel fittings shall be used.
- 5.3 – Size. All system pipe and fittings will be sized in accordance with the system Technical Manual. No substitutions are allowed.
- 5.4 – Joints. No joint sealant shall be used in the discharge piping. Exception: Teflon tape may be used to ensure a snug fit.
- 5.5 – Straps. All system discharge pipe shall be securely fastened by means of pipe hangers and/or pipe straps. UL Listed pipe hangers shall be used.
- 5.6 – Union. A union shall be installed in the discharge piping conveniently close to the cylinder valve to permit disconnection for inspection and service.

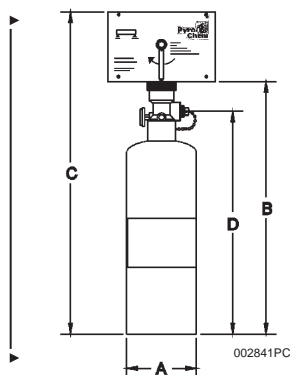

MODEL NO.	A	B	C	D	WEIGHT	MOUNTING BRACKET USED
PCI-15ABC	6.00	21.44	27.19	18.69	30 lbs.	MB-15
PCI-17ABC	8.00	24.81	30.56	22.06	50 lbs.	MB-15
PCI-25sABC	8.00	24.81	30.56	22.06	58 lbs.	MB-15
PCI-35ABC	10.00	29.94	35.69	27.18	71 lbs.	MB-1
PCI-70ABC	12.00	35.31	41.06	32.56	130 lbs.	MB-1
ALL DIMENSIONS IN INCHES						