



*we*innovate cooking

KITCHENS DIAMANTE 70

DEEP FAT FRYERS

Model

D7415/10FRE

Code

CR0994929

General characteristics

- Stainless steel outer coatings and feet.
- Worktops made of 1,5 mm thick, brushed AISI 304 stainless steel.
- Adjustable worktop height from 840 to 900 mm.
- Contoured control panels with controls tilted towards the operator.
- Large knobs that do not protrude from the machine structure.
- Range modularity: 200-400-600-800-1200.
- Simple and effective coupling system.
- Appliances set up for the plinth.
- Vast accessory range.
- Appliances in compliance with CE standards.

2-BASINS ELECTRIC DEEP FAT FRYER 15 LTS.



Technical/functional characteristics

Outer casing and feet in stainless steel. Adjustable worktop height, ranging from 840 to 900 mm. AISI 18/10 stainless steel pan, with cool zone and foam area. Oil discharge tap. Oil drip pan available upon request. Safety thermostat (230°C) to prevent oil overheating. Electric model: AISI 304 stainless steel armoured heaters positioned in the bowl for heating operations; can be rotated more than 90°.

Technical Data

Model	D7415/10FRE
Width (mm)	800,00
Depth (mm)	730,00
Height (mm)	870,00
VOLUME	0,75
WEIGHT	116,00
SUPPLY	
Gas power	
Electric power	24
Internal ovens dimension	
OVEN CAPACITY	
Plate dimensions (mm)	
TANK DIMENSIONS	
Tank capacity (l)	

DEEP FAT FRYERS

Model
D7415/10FRE

Code
CR0994929

D7415/10 FRE

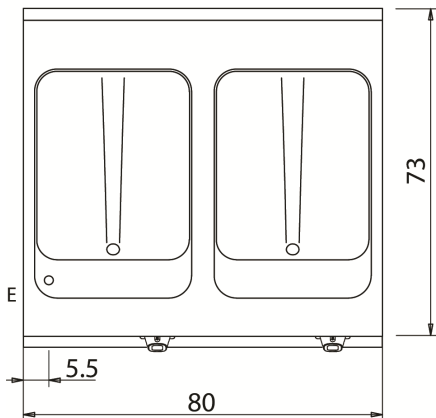
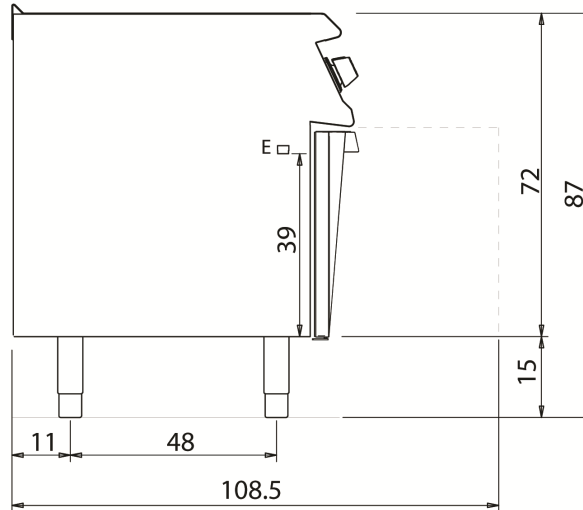
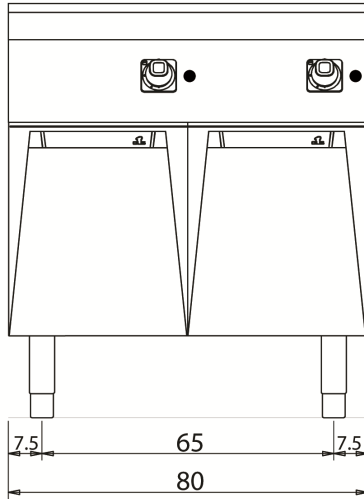

KEY

- E power supply
- G gas connection
- H2O water inlet
- S water outlet

Connection	Power	Diameter	Supply
Gas connecton			
Electric connecton	24	400	
Cold water connecton			0
Hot water connecton			
Cold soft water connecton			
Drain (∅)			
2° Drain (∅)			