



*we*innovate cooking

KITCHENS XXLINE

XXLINE

Model

SDFT12ELC

Code

CR0957039

General characteristics

The XXLine is a large range for professional cooking including 6 functional units, which are flexible and particularly suitable for high-performance catering.

A perfect synthesis of efficiency, productivity and modern technology for catering.

ELECTRIC GRIDDLE PLATES CHROME VERSION

XXLine

Electric Griddle Plates Chrom
Version



Technical/functional characteristics

- 22,5 kW total power
- 3 independent heating zones (110°-280° C)
- Smooth or combined (1/2 ribbed and 1/2 smooth) chromed plate
- Dimensions: 1200x920x280 mm
- Cooking surface: 1120x750 mm
- Cooking plate thickness: 15 mm
- Heaters in AISI 304 s/s embedded in cast aluminum plates
- Tilt-up plate for easy maintenance

Technical Data

Model	SDFT12ELC
Width (mm)	1.200,00
Depth (mm)	920,00
Height (mm)	280,00
VOLUME	0,31
WEIGHT	0,00
SUPPLY	
Gas power	
Electric power	
Internal ovens dimension	
OVEN CAPACITY	
Plate dimensions (mm)	
TANK DIMENSIONS	
Tank capacity (l)	

XXLINE

Model
SDFT12ELC

Code
CR0957039

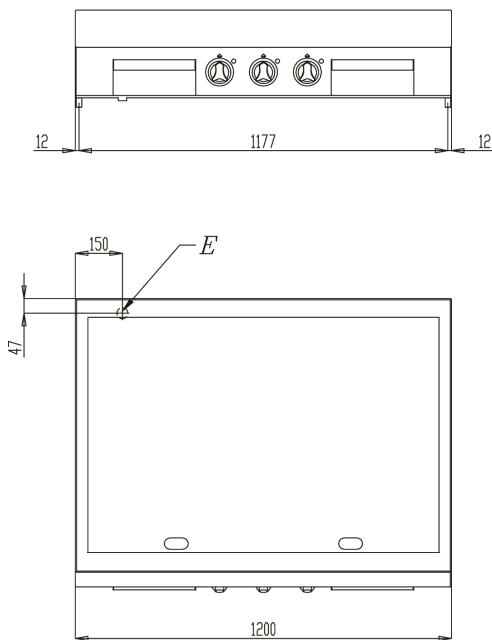

SDFT12ELC

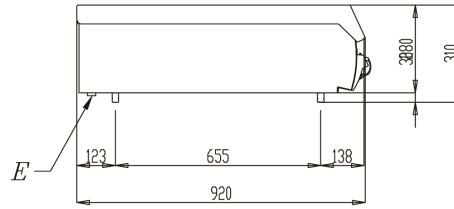

KEY

- E power supply
- G gas connection
- H2O water inlet
- S water outlet

Connection	Power	Diameter	Supply
Gas connecton			
Electric connecton			
Cold water connecton			
Hot water connecton			
Cold soft water connecton			
Drain (∅)			
2° Drain (∅)			