



*we*innovate cooking

KITCHENS DIAMANTE 90

BOILING PANS

Model

D94/10PED15

Code

CR0991149

General characteristics

Stainless steel outer coatings and feet.
Worktops made of 2 mm thick, brushed AISI 304 stainless steel.
Adjustable worktop height from 840 to 900 mm.
Contoured control panels with controls tilted towards the operator.
Large knobs that do not protrude from the machine structure.
Range modularity: 200-400-600-800-1200.
Simple and effective coupling system.
Appliances set up for the plinth.
Vast accessory range.
Appliances in compliance with CE standards.

ELECTRIC BOILING PAN 150 LT. DIRECT HEATING



Technical/functional characteristics

Outer casing and feet in stainless steel. Adjustable worktop height, ranging from 840 to 900 mm. Adjustable worktop height, ranging from 840 to 900 mm. AISI 304 stainless steel pan with base in AISI 316 stainless steel. Water loading using the tap and both hot or cold water may be loaded. Front discharge with 2-inch chrome brass taps. Direct electric model: 3 stainless steel heaters mounted to the external surface of the appliance base for heating operations.

Technical Data

Model	D94/10PED15
Width (mm)	800,00
Depth (mm)	900,00
Height (mm)	870,00
VOLUME	1,30
WEIGHT	167,00
SUPPLY	EL
Gas power	
Electric power	12
Internal ovens dimension	
OVEN CAPACITY	
Plate dimensions (mm)	
TANK DIMENSIONS	Ø=600
Tank capacity (l)	150Lt.

BOILING PANS

Model
D94/10PED15

Code
CR0991149

D94/10 PED15

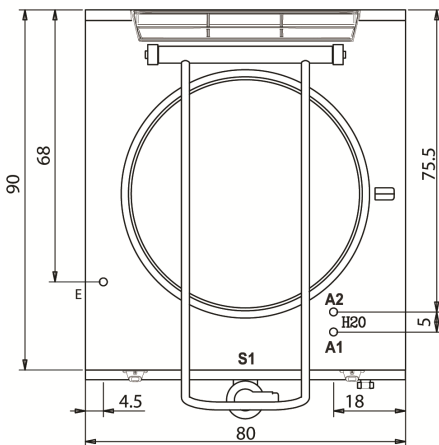
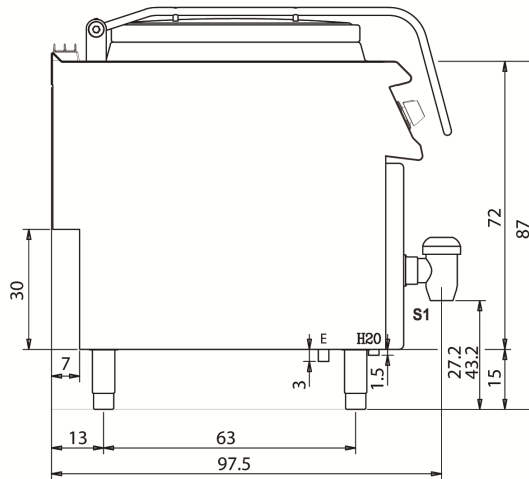
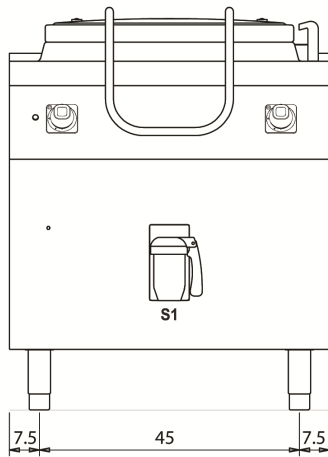

KEY

- E power supply
- G gas connection
- H2O water inlet
- S water outlet

Supply

Gas connecton			
Electric connecton	12	400	
Cold water connecton		3/4"	0
Hot water connecton		3/4"	
Cold soft water connecton			
Drain (∅)		2"	
2° Drain (∅)			