

Now Available in all PS500 Series Ovens!



# Impingement Plus<sup>®</sup> Energy Management System\*

# SAVE up to 30% on your energy costs! \*\*

- Higher quality bake
- Improved Air Flow
- Stackable 3-4 high
- Quieter
- More reliable design
- Less radiant heat to environment
- Greater capacity/ footprint

\* Patented  
\*\* Based upon tests conducted by Pacific Gas and Electric



PS570



PS555



PS540



PS536



PS520

PS520



Bottom View

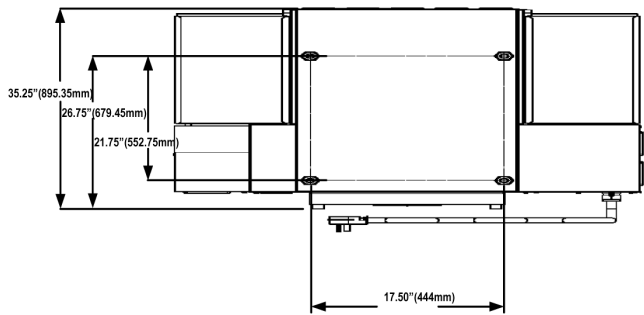

- 18" wide conveyor
- 20" long baking chamber
- Stackable up to 3 high
- Available in gas and electric

	Heating Zone	Baking Area	Belt Length	Belt Width	Overall Length (exit tray not included)	Height	Depth (without window)	Max. Operating Temp.	Bake Time Range	Ship Wt.	Ship Cube
PS520-1 with 4" leg extensions	20" 510mm	2.5sq. ft. .23m <sup>2</sup>	42" 1067mm	18" 457mm	42" 1067mm	21-3/4" to 23-1/4"	35-1/4" 1010mm	550°F 288°C	2:40-28:50 min.	325lbs. 147.4kg	22.1 ft. <sup>3</sup> .62m <sup>3</sup>

### Capacity Comparisons

	6"	10"	12"	14"	16"
PS520	100	28	24	14	12
PS536	185	72	40	27	23
PS540	333	120	67	57	50
PS555	454	165	150	78	68
PS570	577	210	177	100	87

6 minute bake • Capacity per oven per hour • Pizza or other round products



1400 Toastmaster Drive • Elgin, IL 60120  
Phone: 877-34-OVENS / 877-346-8367  
www.middleby.com



# PS500 Series of Conveyor Ovens

Featuring Impigment Plus and the Energy Management System

**SAVE**  
up to **30%**  
on your energy costs!

## PS570

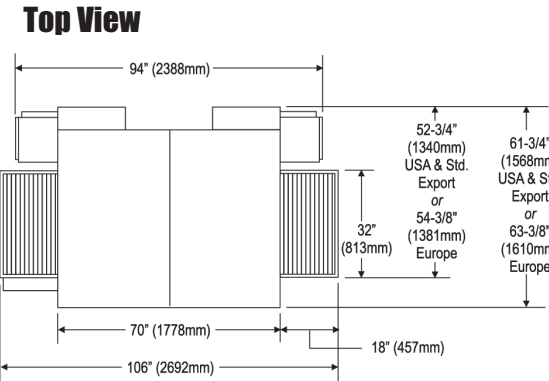

- 32" wide conveyor
- 70" long baking chamber
- Stackable up to 4 high
- Available in gas and electric

	Heating Zone	Baking Area	Belt Length	Belt Width	Depth	Depth CE	Height	Max. Operating Temp.	Bake Time Range	Ship Wt.	Ship Cube
PS570-1 with 19" (483mm) leg extensions	70" 1778mm	15.5sq. ft. 1.44m <sup>2</sup>	106" 2692mm	32" 813mm	61-3/4" 1568mm	63-3/8" 1610mm	48-1/4" 1226mm	550°F 288°C	4-29:50 min.	1750lbs. 795kg	160 ft. <sup>3</sup> 4.5m <sup>3</sup>

## PS540

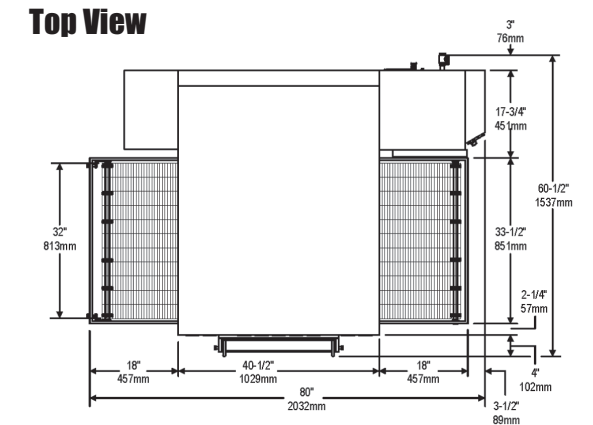

- 32" wide conveyor
- 40" long baking chamber
- Stackable up to 4 high
- Available in gas and electric

	Heating Zone	Baking Area	Belt Length	Belt Width	Overall Length (exit tray not included)	Height	Depth	Max. Operating Temp.	Bake Time Range	Ship Wt.	Ship Cube
PS540-1 with 15" leg extensions	40" 1016mm	8.9sq. ft. .83m <sup>2</sup>	76.1/2" 1943mm	32" 813mm	80" 2032mm	47-1/4" 1200mm	61-3/8" 1559mm	550°F 288°C	3-29 min.	1,100lbs. 499kg	132 ft. <sup>3</sup> 3.7m <sup>3</sup>

## PS555

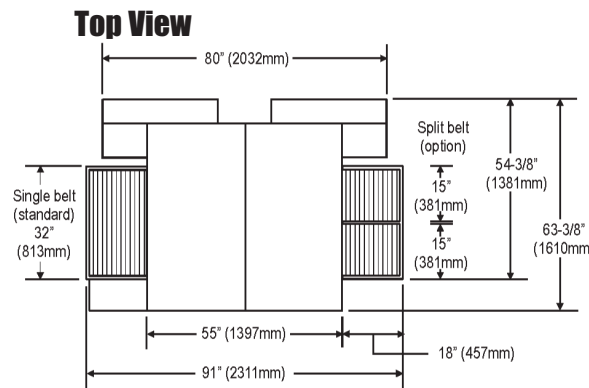

- 32" wide conveyor
- 55" long baking chamber
- Stackable up to 4 high
- Available in gas and electric

	Heating Zone	Baking Area	Belt Length	Belt Width	Depth	Depth CE	Height	Max. Operating Temp.	Bake Time Range	Ship Wt.	Ship Cube
PS555-1 with 19" (483mm) leg extensions	55" 1397mm	12.2sq. ft. 1.13m <sup>2</sup>	91" 2311mm	32" 813mm	61-3/4" 1568mm	63-3/8" 1610mm	48-1/4" 1226mm	550°F 288°C	4-29:50 min.	1250lbs. 568kg	160 ft. <sup>3</sup> 4.5m <sup>3</sup>

## PS536

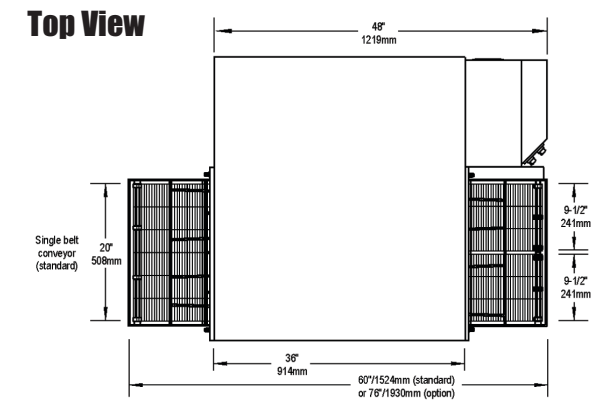

- 20" wide conveyor
- 36" long baking chamber
- Stackable up to 3 high
- Available in gas and electric

	Heating Zone	Baking Area	Belt Length	Belt Width	Overall Length (exit tray not included)	Height	Depth (without window)	Max. Operating Temp.	Bake Time Range	Ship Wt.	Ship Cube
PS536-1 with 17.5" (466mm) leg extensions	36" 914mm	5sq. ft. 0.465m <sup>2</sup>	60" 1524mm or 76"	20" 508mm	60" 1524mm or 76"	43.5" 1105mm	39-3/4" 1010mm	550°F 288°C	2-40-29:50 min.	658lbs. 299kg	35.2 ft. <sup>3</sup> 0.99m <sup>3</sup>