



*we*innovate cooking

KITCHENS DIAMANTE 70

BAIN MARIES

Model

D74/10CBG

Code

CR0990329

General characteristics

- Stainless steel outer coatings and feet.
- Worktops made of 1,5 mm thick, brushed AISI 304 stainless steel.
- Adjustable worktop height from 840 to 900 mm.
- Contoured control panels with controls tilted towards the operator.
- Large knobs that do not protrude from the machine structure.
- Range modularity: 200-400-600-800-1200.
- Simple and effective coupling system.
- Appliances set up for the plinth.
- Vast accessory range.
- Appliances in compliance with CE standards.

GAS BAIN-MARIE ON OPEN CUPBOARD



Technical/functional characteristics

- Outer casing and feet in stainless steel.
- Adjustable worktop height, ranging from 840 to 900 mm.
- Pan that are suitable to contain bowls that are 150 mm high.
- Perforated false bottom to support recipients.
- Temperature regulation from 30° to 90°C.
- Bowl equipped with overflow device.
- Burner controlled by thermocouple thermostat safety valve and piezo electric lighter.

Technical Data

Model	D74/10CBG
Width (mm)	800,00
Depth (mm)	730,00
Height (mm)	870,00
VOLUME	0,80
WEIGHT	69,00
SUPPLY	
Gas power	6
Electric power	
Internal ovens dimension	
OVEN CAPACITY	
Plate dimensions (mm)	
TANK DIMENSIONS	
Tank capacity (l)	

BAIN MARIES

Model
D74/10CBG

Code
CR0990329

D74/10 CBG

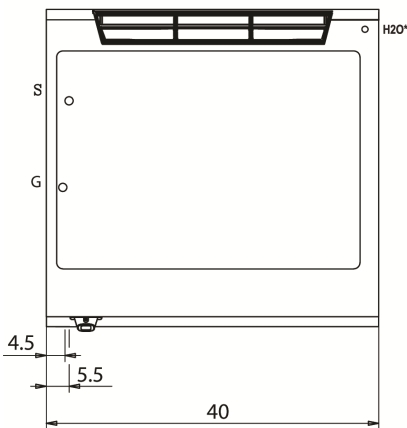
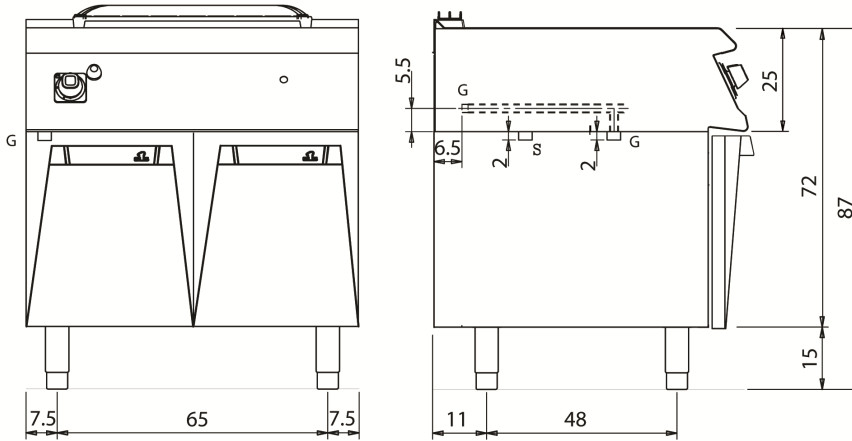

KEY

- E power supply
- G gas connection
- H2O water inlet
- S water outlet

Connection	Power	Diameter	Supply
Gas connecton	6	1/2"	
Electric connecton			
Cold water connecton			
Hot water connecton			
Cold soft water connecton			
Drain (∅)		1/2"	
2° Drain (∅)			