



*we*innovate cooking

KITCHENS DIAMANTE 90

TILTING BRATT PANS

Model

D96/10KBGIM

Code

CR0990739

General characteristics

- Stainless steel outer coatings and feet.
- Worktops made of 2 mm thick, brushed AISI 304 stainless steel.
- Adjustable worktop height from 840 to 900 mm.
- Contoured control panels with controls tilted towards the operator.
- Large knobs that do not protrude from the machine structure.
- Range modularity: 200-400-600-800-1200.
- Simple and effective coupling system.
- Appliances set up for the plinth.
- Vast accessory range.
- Appliances in compliance with CE standards.

GAS BRATT PAN WITH MOTORIZED TILTING 120LT.WITH BOTTOM MADE IN COMPOUND



Technical/functional characteristics

Outer casing and feet in stainless steel. Adjustable worktop height, ranging from 840 to 900 mm. Strong double-walled self-balancing lid, 2 mm thick AISI 304 stainless steel cooking pot, with bottom made in compound. Thermostatically-controlled cooking temperature range from 100 to 280°C. Gas model: chrome steel burner for cooking operations. Safety valve with thermocouple, electric ignition. Motorized bowl lifting.

Technical Data

Model	D96/10KBGIM
Width (mm)	1.200,00
Depth (mm)	900,00
Height (mm)	870,00
VOLUME	1,50
WEIGHT	210,00
SUPPLY	GAS-EL
Gas power	24
Electric power	0.2
Internal ovens dimension	
OVEN CAPACITY	
Plate dimensions (mm)	
TANK DIMENSIONS	1125x600x175/200h
Tank capacity (l)	120Lt.

TILTING BRATT PANS

Model
D96/10KBGIM

Code
CR0990739

D96/10 KBGIM

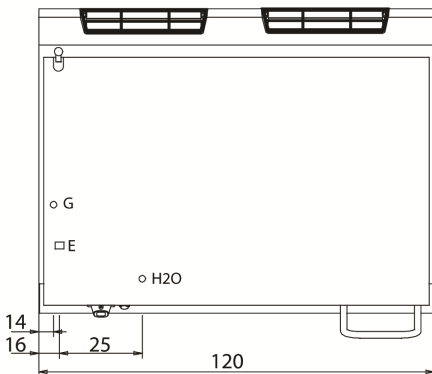
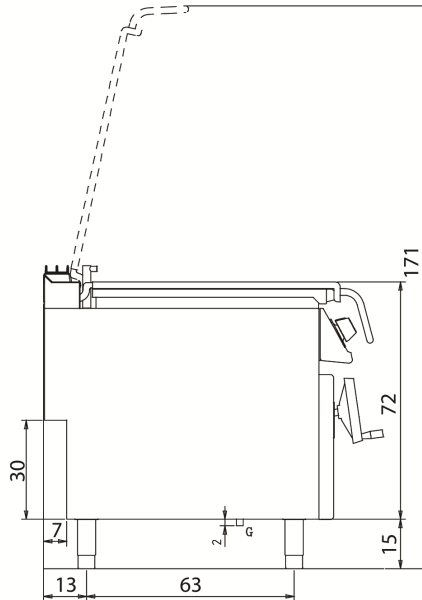
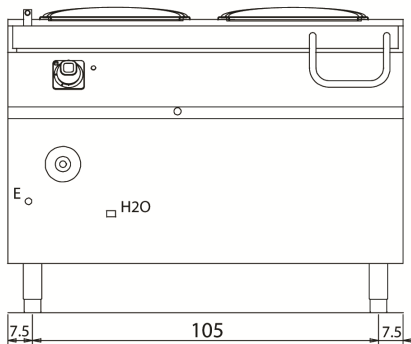

KEY

- E power supply
- G gas connection
- H2O water inlet
- S water outlet

Supply

Gas connecton	24	1/2"	
Electric connecton	0.2	230	
Cold water connecton		3/4"	0
Hot water connecton			
Cold soft water connecton			
Drain (∅)			
2° Drain (∅)			