

# MAR 306

## Modular Ice Machine up to 2000 kg

Item #:
Project:
Quantity:



### FEATURES

- Scale ice machine, in "compact system" version; built-in unit. Storage bin not supplied, to be purchased separately.
- AISI304 Stainless steel evaporator and ice scraper blade. Redesigned evaporator compartment end-walls.
- Electromechanical control panel.
- Electrical protections, rotation speed & reverse phase controls.
- Low- water sensor protection. Semi-hermetic compressor. Storage bin thermostatic ice level sensor.
- Drive motor / gear reducer with V-Belt drive.
- Stainless steel panels in scotch-brite finish, with rounded corners, easy to remove for maintenance.
- ON/OFF manual switch, with weekly programmable timer.



MAR 306  
Scale ice  
Residual water content 2%  
Thickness 1 or 2 mm

### CONDENSING SYSTEM

Remote condenser  
Water cooled

### RECOMMENDED BINS

Head	Bins		kg
MAR 306	●	<b>UBH1600</b>	812
	●	<b>UBH2250</b>	1068
	●	<b>SIS1350</b>	613 + 73 + 73

### REFRIGERANT GAS

R404A

### VOLTAGE V/Hz/ph

230/60/3  
380/60/3N  
400/50/3N  
400/60/3

### LEGEND:

- ✓ : Perfect combination between ice maker and bin
- : Ice chute cut-out performed upon installation
- CBTxxxxxxxx : need additional bin top

Certifications:



### OPERATING REQUIREMENTS

	Minimum	Maximum
Air temperature	10°C	43°C
Water temperature	5°C	38°C
Water pressure	1 bar (14 psi)	5 bar (70 psi)
Electrical voltage	-10%	+10%

**IMPORTANT NOTICE:**  
Models and specifications are subject to change without notice. This spec sheet is meant for commercial purpose only. For technical documentation please refer to our service manuals.

Download our free **App Scotsman Ice**  
Apple store  
Google play  
Windows store



[www.scotsman-ice.it](http://www.scotsman-ice.it)  
[www.scotsman-ice.com](http://www.scotsman-ice.com)

Modular Ice Machine up to 2000 kg

# MAR 306

## Modular Ice Machine up to 2000 kg

Item #:
Project:
Quantity:

Modular Ice Machine up to 2000 kg

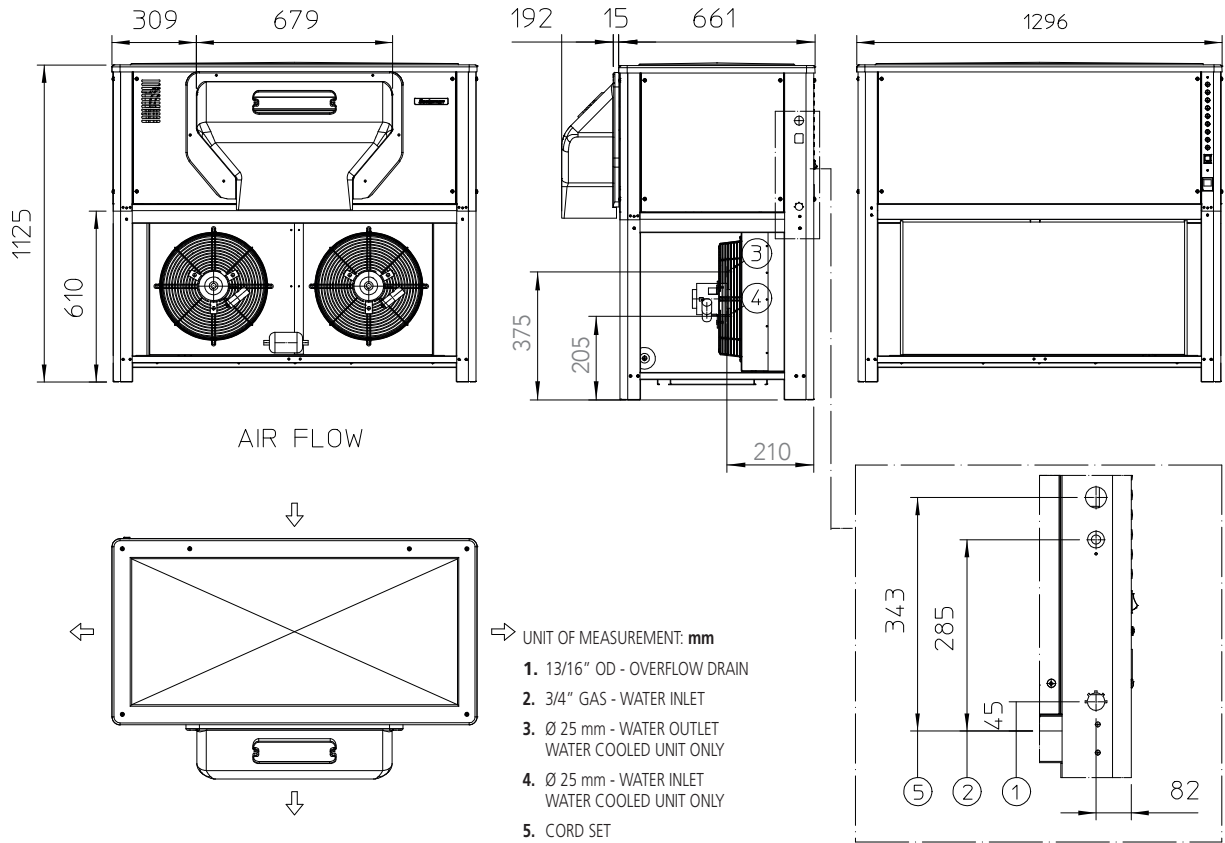

UNIT DATA			Cooling Requirements (Te -25°C; Tc +45.0°C)		Circuit wires		Max. fuse size					
			Version	Voltage	Btu/h	W	No.	Ømm <sup>2</sup>	A			
Size (W x D x H)	1296 x 676 x 1125 mm		MAR 306 ASR	400/50/3N	44358	13000	5	4.0	32			
Net weight	393 kg		MAR 306 ASR	230/60/3	44358	13000	4	10.0	100			
SHIPPING DATA			MAR 306 ASR	380/60/3N	44358	13000	5	4.0	32			
			MAR 306 WS	400/50/3N	44358	13000	5	4.0	32			
Carton (W x D x H)	1410 x 790 x 1250 mm		MAR 306 WS	400/60/3	44358	13000	4	4.0	32			
Weight	416 kg											
			24 h ice production kg °C Amb. / °C Water						Energy consumption (*)		Water usage(*)	Instant power
Version	Condensation	Voltage	10°C/10°C		21°C/10°C		32°C/21°C		kWh/100 kg	kWh/24h	l/h	W
			1 mm	2 mm	1 mm	2 mm	1 mm	2 mm				
MAR 306 ASR	Remote	400/50/3N	2000	1800	1950	1755	1650	1485	11.6	200.0	68.8	8750
MAR 306 ASR	Remote	230/60/3	2000	1800	1950	1755	1650	1485	13.0	215.0	68.8	9100
MAR 306 ASR	Remote	380/60/3N	2000	1800	1950	1755	1650	1485	11.6	200.0	68.8	8150
MAR 306 WS	Water	400/50/3N	2000	1800	1950	1755	1650	1485	11.6	200.0	416.7	10000
MAR 306 WS	Water	400/60/3	2000	1800	1950	1755	1650	1485	11.6	200.0	416.7	10000

(\*) Data refer to 32°C Amb. / 21°C Water temperature conditions