



Abbattitore di Temperatura
Blast chiller



Gelateria
Icecream



Ciclo conservazione
Conservation cycle



Scongelamento
Thawing



Programmi abbattimento
Chilling programs



Ozono
Ozone

Caratteristiche

- Spessore isolamento pareti 70mm
- Costruito in AISI304
- Sbrinamento a Gas caldo e a ventilazione forzata
- Controllo Touch da 7"
- Funzioni presenti : Abbattimento positivo , negativo , continuo , abbattimento automatico, scongelamento, conservazione, ciclo gelato , programmi memorizzabili ,report allarmi HACCP
- Importazione ed esportazione dati con USB
- Unità condensante a bordo

Opzioni

- Ciclo sanitizzazione ad ozono opzionale
- Condensazione ad acqua opzionale
- Versioni a 60 Hz
- Pavimento speciale H 20 mm
- Scocca a pannelli smontabile



Features

- Thickness insulation walls 70 mm
- AISI 304 stainless steel construction
- Hot gas defrosting and Forced ventilation
- 7" Touch control
- Functions available: Blast chilling, blast freezing, Blast freezing continuous, automatic blast chilling - thawing - ice cream- -conservation- storable cycle programs - HACCP report alarms

- Upload and Download data with USB
- Condensing group on board

Optional

- Sanitizing ozone cycle (option)
- Option Water condensing version
- 60Hz Versions
- Special floor H = 20 mm
- Body with removable panels

Capacità - Capacity



80 kg
+90°C → +3°C



65 kg
+90°C → -18°C



1
Carrello forni gastronomia
Combi steamer trolley
GN1/1 - GN 2/1
600 x 800 mm

Predisposto
connessione **WI-FI**
Predisposed **WI-FI**
connection



Caratteristiche - Features

Codice Prodotto Code number	CT20-80	CT20-80 RE	CT20-110 RE
Alimentazione Elettrica Power supply	400V/3N/50HZ	400V/3N/50HZ	400V/3N/50HZ
Lunghezza esterna Outside length	890 mm	890 mm	890 mm
Profondità Depth	1335 mm	1335 mm	1335 mm
Altezza esterna Height	2410 mm	2410 mm	2410 mm
Dimensione max carrello (LxPxH) Max Trolley Dimensions (WxDxH)	680 x 860 x 1850 mm	680 x 860 x 1850 mm	680 x 860 x 1850 mm
Potenza assorbita Absorbed power	3900 W	475 W + 3425 W	475 W + 3900 W
Resa abbattimento Output chilling (+90°C/+3°C)	80 kg	80 kg	110 kg
Resa surgelazione Output freezing (+90°C/-18°C)	65 kg	65 kg	95 kg
Peso netto/lordo Net/*Gross Weight	353 / 430 kg	255 / 332 kg	255 / 332 kg
Dati spedizione (LxPxH) Shipment data (WxDxH)	990 x 1532 x 2570 mm 430 kg	990 x 1532 x 2570 mm 332 kg	990 x 1532 x 2570 mm 332 kg
CARATTERISTICHE UNITÀ REMOTA REMOTE UNIT FEATURES	Unità a Bordo No remote Unit	Unità Remota - Remote Unit (distanza max 15 m - max distance 15 m)	
Alimentazione Voltage	-	400V/3N/50HZ	400V/3N/50HZ
Potenza Frigorifera Refrigeration Power (-20°C/+45°C)	5400 W	5400 W	7270 W
Sbrinamento Defrost	Gas Caldo - Hot Gas	Gas Caldo - Hot Gas	Gas Caldo - Hot Gas
Cavo alimentazione Cable size (5 m included)	5 x 2.5 mm	5 x 2.5 mm	5 x 2.5 mm
Diametro Tubo Mandata Diameter Discharge Pipe mm	-	12	12
Diametro Tubo Aspirazione Diameter Suction Pipe mm	-	22	22
Diametro Tubo Gas Caldo Diameter Hot Gas Pipe mm	-	10	10
Fluido refrigerante Refrigeration Fluid	2,5 kg R 452a (GWP=2141)	R 452a (GWP=2141)	R 452a (GWP=2141)
Dati spedizione (LxPxH) Shipment data (WxDxH)	-	700 x 1100 x 750 mm (170 Kg)	700 x 1100 x 750 mm (170 Kg)

Dimensioni- Dimensions

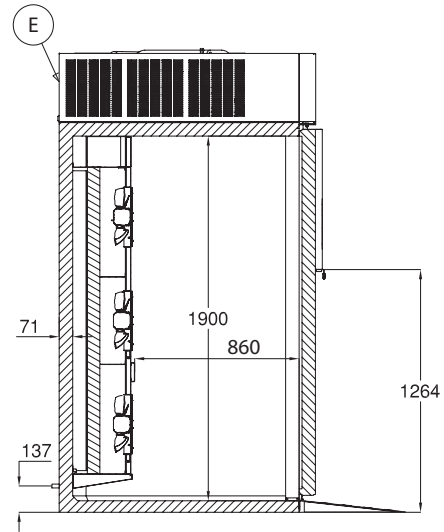
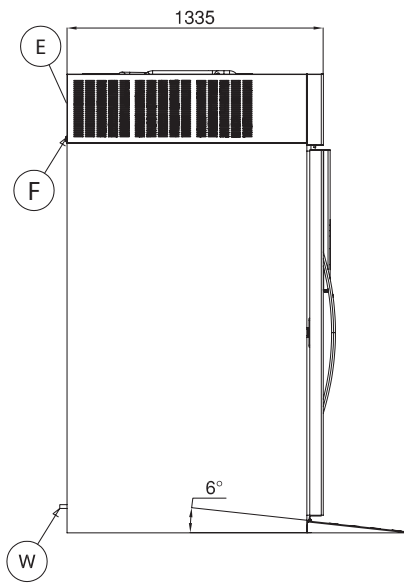
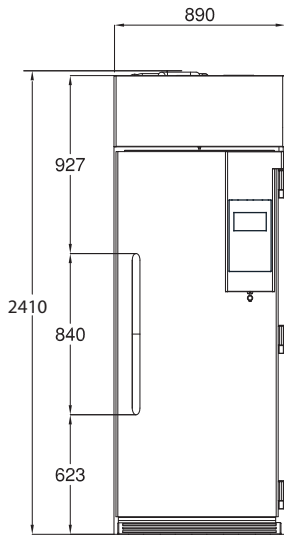

FLUSSO ARIA
AIR FLOW

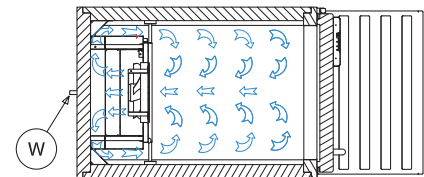
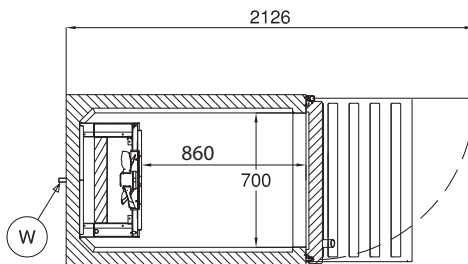
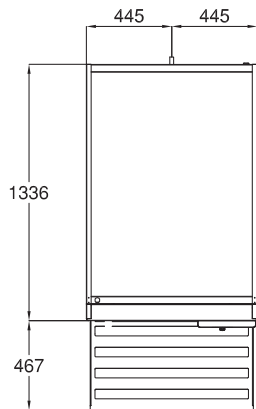

Funzioni / Functions

INTERFACCIA 7" TOUCH 7" TOUCH INTERFACE

Versione Version	Abbattimento Blast chiller cycles	Ciclo gelato Ice cream cycle	Ciclo conservazione Conservation cycle	Ciclo scongelamento Thawing cycles	Ciclo Ozono Ozone cycle	Sbinamento gas caldo Hot gas defrosting	Programmi memorizzati Stored Programs	Ventil. Evaporatore a velocità variabile Variable speed fans evaporator	Resistenza a potenza variabile Variable power resistance	Controllo dinamico Set Dynamic Frost Control	Carico/Scarico dati-USB Load/Download data-USB
START	●	●	●	●	●	●	●	●	●	●	●
FULL	●	●	●	●	●	●	●	●	●	●	●

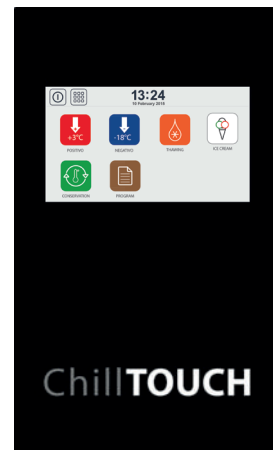

Scavo Areato - Areated Excavation

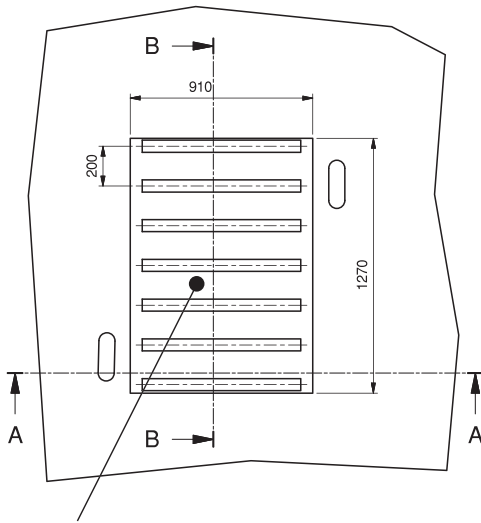

cavo - Excavation

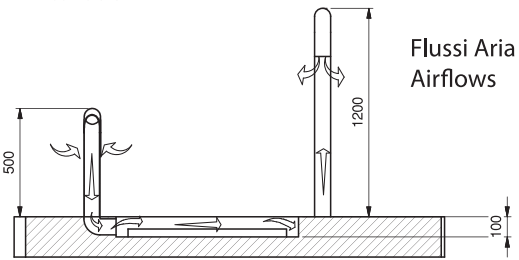

A-A

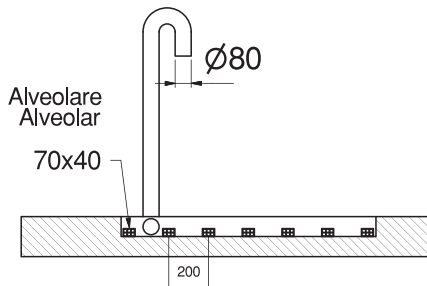

B-B

Soluzione per funzionamento 24h/giorno
For running 24 hours a day

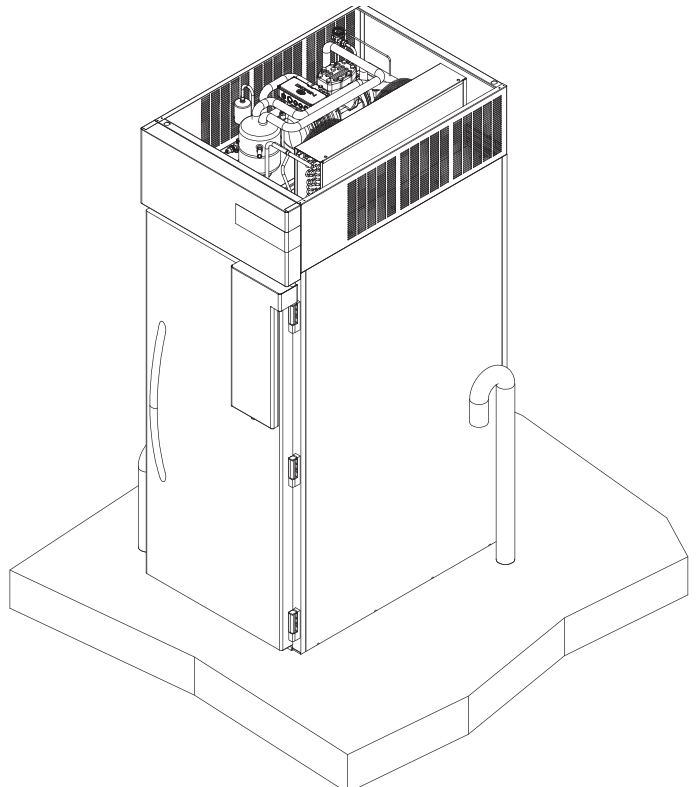
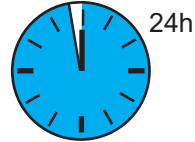

CT20.80 400V/3N/50Hz Blast chiller Multifunction

Unita' remota - Remote unit features (E20.80 - E20.110)

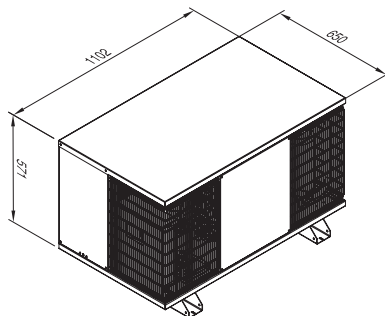
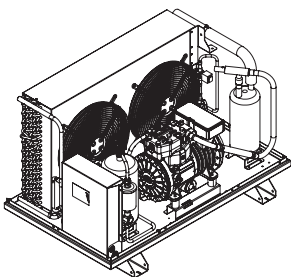

UNITA' CONDENSATRICE CARENTA
 CONDENS. UNIT WITH BOX