



*we*innovate cooking

KITCHENS DIAMANTE 70

ELECTRIC RANGES

Model

D72/10CEPT

Code

CR0993749

General characteristics

- Stainless steel outer coatings and feet.
- Worktops made of 1,5 mm thick, brushed AISI 304 stainless steel.
- Adjustable worktop height from 840 to 900 mm.
- Contoured control panels with controls tilted towards the operator.
- Large knobs that do not protrude from the machine structure.
- Range modularity: 200-400-600-800-1200.
- Simple and effective coupling system.
- Appliances set up for the plinth.
- Vast accessory range.
- Appliances in compliance with CE standards.

2-ROUND-HOTPLATE ELECTRIC RANGE ON OPEN CUPBOARD



Technical/functional characteristics

- Outer casing and feet in stainless steel.
- Adjustable worktop height, ranging from 840 to 900 mm.
- Shaped cooker control panel with knobs slanted towards the operator.
- Round plates version 220mm diameter and 2.6 kW.

Technical Data

Model	D72/10CEPT
Width (mm)	400,00
Depth (mm)	730,00
Height (mm)	870,00
VOLUME	0,40
WEIGHT	45,00
SUPPLY	
Gas power	
Electric power	5.2
Internal ovens dimension	
OVEN CAPACITY	
Plate dimensions (mm)	
TANK DIMENSIONS	
Tank capacity (l)	

ELECTRIC RANGES

Model
D72/10CEPT

Code
CR0993749

D72/10 CEPT

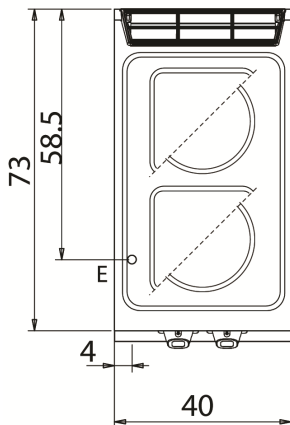
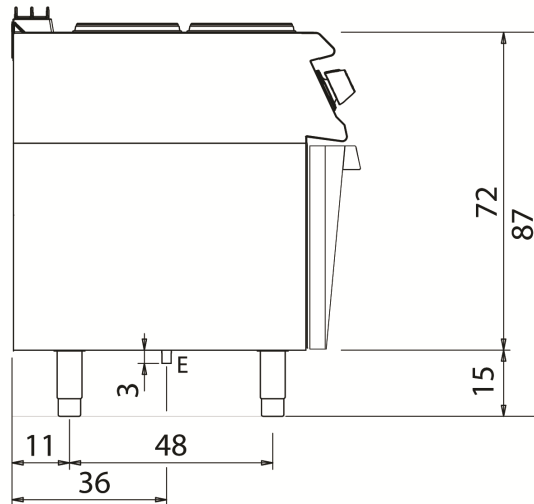
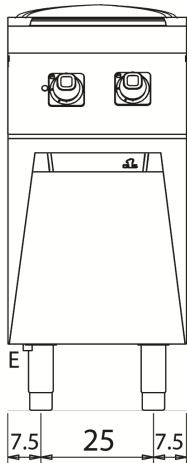

KEY

- E power supply
- G gas connection
- H2O water inlet
- S water outlet

Connection	Power	Diameter	Supply
Gas connecton			
Electric connecton	5.2	400	
Cold water connecton			0
Hot water connecton			
Cold soft water connecton			
Drain (∅)			
2° Drain (∅)			