



*we*innovate cooking

KITCHENS

650 SERIE

ELECTRIC RANGES

Model

OC67EP

Code

CR0853969

General characteristics

The SNACK 650 range by OLIS has been created with a distinctive design for all its equipment, both in the top and single-unit version, with large knobs and an ergonomic shape for the control panels. The wide selection of machines and their high performance make this range the ideal choice for rooms with a limited amount of space that still need efficient machines. The range's modularity allows for endless combinations with installations placed on cabinet bases or tables.

4 ELECTRIC PLATES BOILING TOP



Technical/functional characteristics

The electric cookers are equipped with cast iron hotplates hermetically secured to the top and have a diameter of 180 mm and 220 mm, with a power of 2.6 kW.

Technical Data

Model OC67EP

Width (mm) 700,00

Depth (mm) 650,00

Height (mm) 295,00

VOLUME 0,16

WEIGHT 25,00

SUPPLY EL

Gas power

Electric power 10.4

Internal ovens dimension

OVEN CAPACITY

Plate dimensions (mm)

TANK DIMENSIONS

Tank capacity (l)

ELECTRIC RANGES

Model
OC67EP

Code
CR0853969

OC67EP*

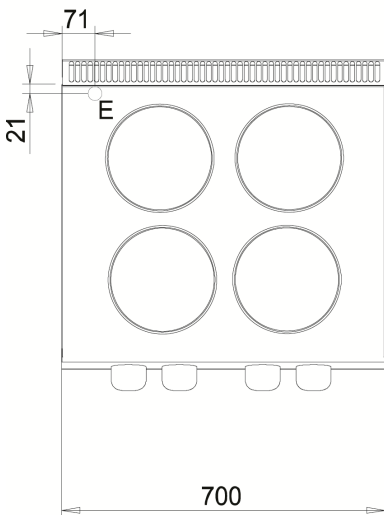
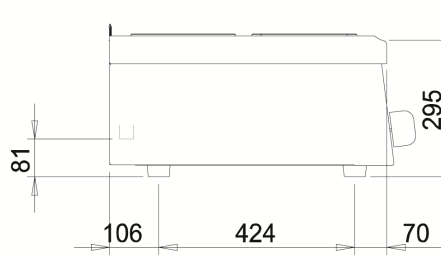
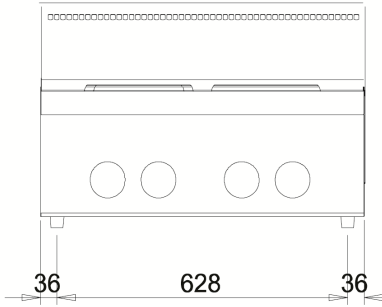

KEY

- E power supply
- G gas connection
- H2O water inlet
- S water outlet

Connection	Power	Diameter	Supply
Gas connecton			
Electric connecton	10.4	400	
Cold water connecton			0
Hot water connecton			
Cold soft water connecton			
Drain (∅)			
2° Drain (∅)			