



*we*innovate cooking

KITCHENS DIAMANTE 70

BAIN MARIES

Model

D74/10CBE

Code

CR0990349

General characteristics

- Stainless steel outer coatings and feet.
- Worktops made of 1,5 mm thick, brushed AISI 304 stainless steel.
- Adjustable worktop height from 840 to 900 mm.
- Contoured control panels with controls tilted towards the operator.
- Large knobs that do not protrude from the machine structure.
- Range modularity: 200-400-600-800-1200.
- Simple and effective coupling system.
- Appliances set up for the plinth.
- Vast accessory range.
- Appliances in compliance with CE standards.

ELECTRIC BAIN-MARIE ON OPER CUPBOARD



Technical/functional characteristics

- Outer casing and feet in stainless steel.
- Adjustable worktop height, ranging from 840 to 900 mm.
- Pan that are suitable to contain bowls that are 150 mm high.
- Perforated false bottom to support recipients.
- Temperature regulation from 30° to 90°C.
- Bowl equipped with overflow device.
- Armoured heater mounted on the outside of the bowl.

Technical Data

Model	D74/10CBE
Width (mm)	800,00
Depth (mm)	730,00
Height (mm)	870,00
VOLUME	0,80
WEIGHT	67,00
SUPPLY	
Gas power	
Electric power	5.4
Internal ovens dimension	
OVEN CAPACITY	
Plate dimensions (mm)	
TANK DIMENSIONS	
Tank capacity (l)	

BAIN MARIES

Model
D74/10CBE

Code
CR0990349

D74/10 CBE

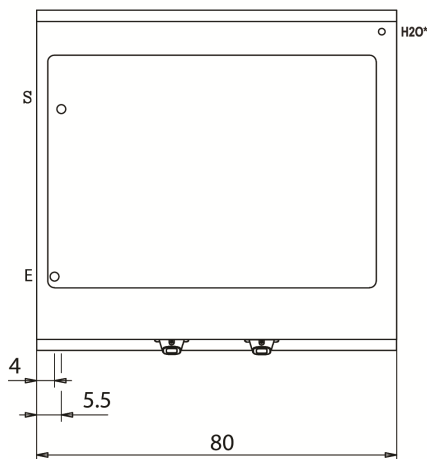
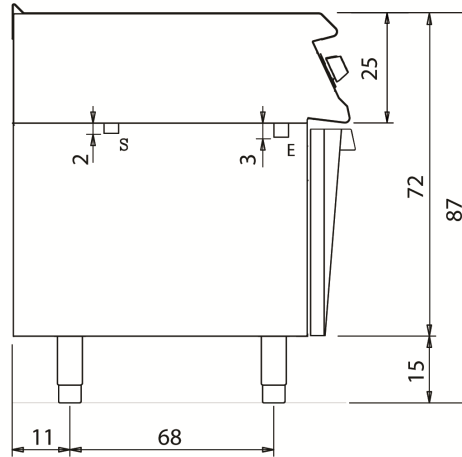
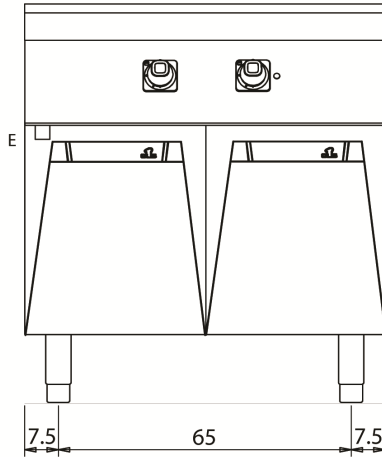

KEY

- E power supply
- G gas connection
- H2O water inlet
- S water outlet

Connection	Power	Diameter	Supply
Gas connecton			
Electric connecton	5.4	400	
Cold water connecton			0
Hot water connecton			
Cold soft water connecton			
Drain (∅)		1/2"	
2° Drain (∅)			