



*we*innovate cooking

# KITCHENS DIAMANTE 70

## ELECTRIC RANGES

Model

D76/10CEEEPT

Code

CR0993809

### General characteristics

- Stainless steel outer coatings and feet.
- Worktops made of 1,5 mm thick, brushed AISI 304 stainless steel.
- Adjustable worktop height from 840 to 900 mm.
- Contoured control panels with controls tilted towards the operator.
- Large knobs that do not protrude from the machine structure.
- Range modularity: 200-400-600-800-1200.
- Simple and effective coupling system.
- Appliances set up for the plinth.
- Vast accessory range.
- Appliances in compliance with CE standards.

### 6-ROUND-HOTPLATE ELECTRIC RANGE ON ELECTRIC OVEN AND HEATED CUPBOARD



### Technical/functional characteristics

- Outer casing and feet in stainless steel.
- Adjustable worktop height, ranging from 840 to 900 mm.
- Shaped cooker control panel with knobs slanted towards the operator.
- Round plates version 220mm diameter and 2.6 kW.
- Electric oven with independently regulated armoured heating elements on oven roof and to the rear.
- Thermostatically-controlled temperature range from 50 to 300°C.
- GN 2/1 oven.

### Technical Data

Model	D76/10CEEEPT
Width (mm)	1.200,00
Depth (mm)	730,00
Height (mm)	870,00
VOLUME	1,10
WEIGHT	140,00
SUPPLY	
Gas power	
Electric power	21.6
Internal ovens dimension	
OVEN CAPACITY	
Plate dimensions (mm)	
TANK DIMENSIONS	
Tank capacity (l)	

### ELECTRIC RANGES

Model  
D76/10CEEPT

Code  
CR0993809

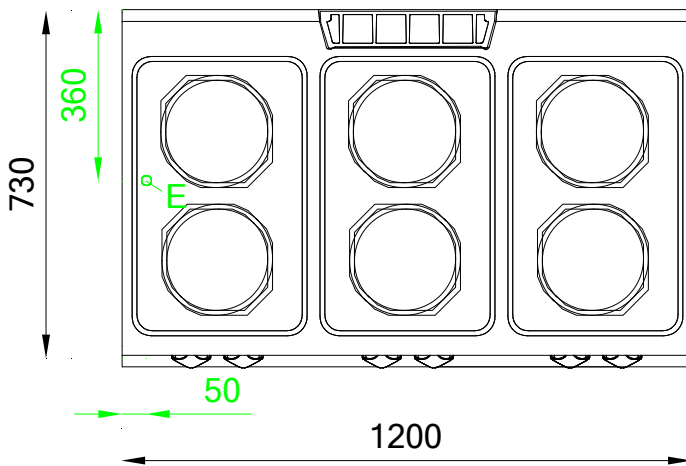
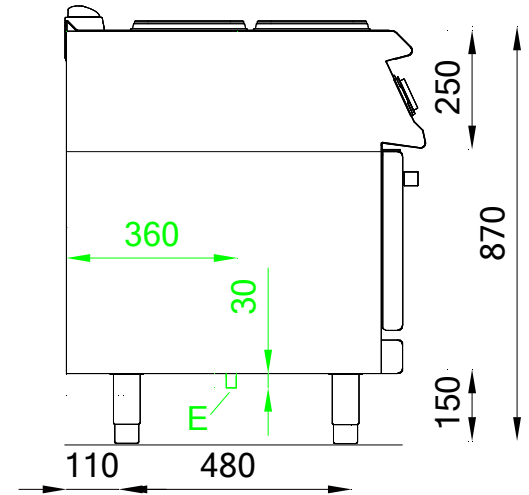
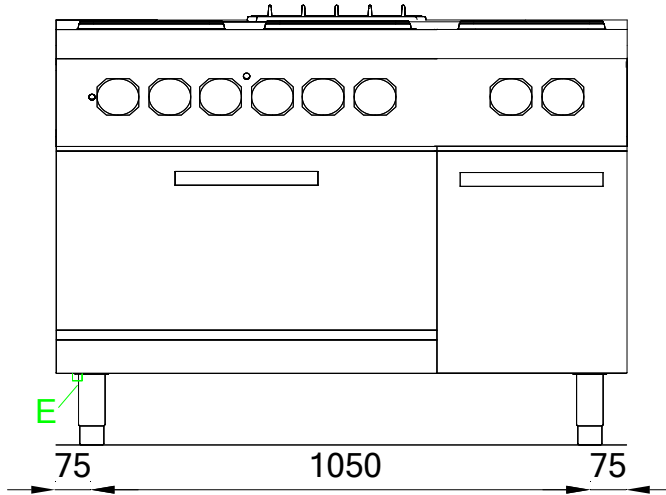

**KEY**

- E power supply
- G gas connection
- H2O water inlet
- S water outlet

Connection	Power	Diameter	Supply
Gas connecton			
Electric connecton	21.6	400	
Cold water connecton			0
Hot water connecton			
Cold soft water connecton			
Drain (∅)			
2° Drain (∅)			