



weinnovate cooking

# KITCHENS DIAMANTE 90

## WOK GAS

Model

D93/10CGW10

Code

CR0991779

### General characteristics

- Stainless steel outer coatings and feet.
- Worktops made of 2 mm thick, brushed AISI 304 stainless steel.
- Adjustable worktop height from 840 to 900 mm.
- Contoured control panels with controls tilted towards the operator.
- Large knobs that do not protrude from the machine structure.
- Range modularity: 200-400-600-800-1200.
- Simple and effective coupling system.
- Appliances set up for the plinth.
- Vast accessory range.
- Appliances in compliance with CE standards.

## WOK 1 BURNER GAS RANGE 10KW ON OPEN CUPBOARD



### Technical/functional characteristics

- Outer casing and feet made of stainless steel.
- Worktops with a 20/10 thickness with 550x520 mm or 950x520 mm for the 700 range.
- Right rear drain with a 22 mm diameter, configured for earth connection.
- With grease collection draw (approx. 2/3 lt capacity).

### Technical Data

Model	D93/10CGW10
Width (mm)	600,00
Depth (mm)	900,00
Height (mm)	870,00
VOLUME	0,47
WEIGHT	0,00
SUPPLY	
Gas power	10
Electric power	
Internal ovens dimension	
OVEN CAPACITY	
Plate dimensions (mm)	
TANK DIMENSIONS	
Tank capacity (l)	

WOK GAS

Model  
D93/10CGW10

Code  
CR0991779

**D93/10CGPW10**

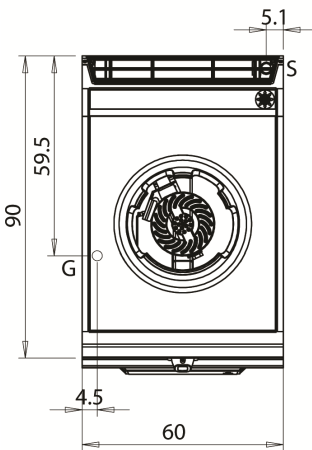
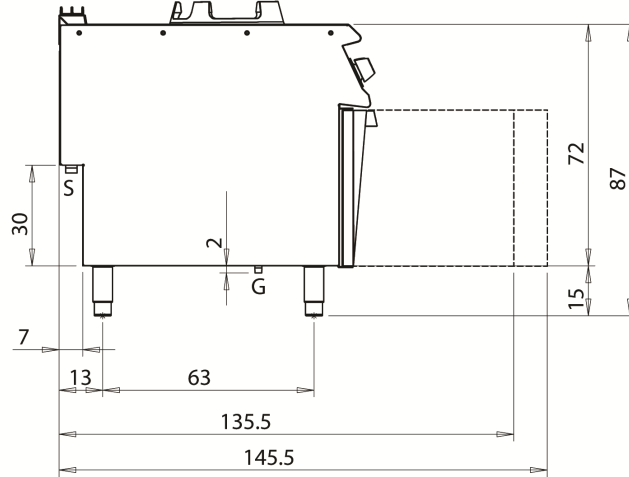
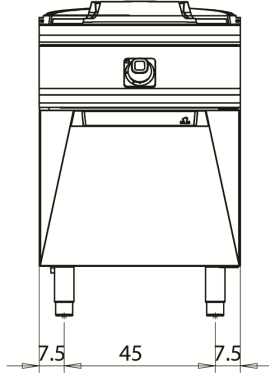

**KEY**

- E power supply
- G gas connection
- H2O water inlet
- S water outlet

Connection	Power	Diameter	Supply
Gas connecton	10	1/2"	
Electric connecton			
Cold water connecton			
Hot water connecton			
Cold soft water connecton			
Drain (Ø)			
2° Drain (Ø)			