



*we*innovate cooking

KITCHENS DIAMANTE 70

EL.SOLID TOP RANGES

Model

D74/10CTE

Code

CR0990209

General characteristics

- Stainless steel outer coatings and feet.
- Worktops made of 1,5 mm thick, brushed AISI 304 stainless steel.
- Adjustable worktop height from 840 to 900 mm.
- Contoured control panels with controls tilted towards the operator.
- Large knobs that do not protrude from the machine structure.
- Range modularity: 200-400-600-800-1200.
- Simple and effective coupling system.
- Appliances set up for the plinth.
- Vast accessory range.
- Appliances in compliance with CE standards.

ELECTRIC SOLID TOP ON OPEN CUPBOARD



Technical/functional characteristics

- Outer casing and feet in stainless steel.
- Adjustable worktop height, ranging from 840 to 900 mm.
- Heating for each area is carried out by radiant elements controlled by a safety thermostat.
- Temperature controlled by thermostat with a range from 50 to 400°C.

Technical Data

Model	D74/10CTE
Width (mm)	800,00
Depth (mm)	730,00
Height (mm)	870,00
VOLUME	0,80
WEIGHT	125,00
SUPPLY	
Gas power	
Electric power	10
Internal ovens dimension	
OVEN CAPACITY	
Plate dimensions (mm)	
TANK DIMENSIONS	
Tank capacity (l)	

EL.SOLID TOP RANGES

Model
D74/10CTE

Code
CR0990209

D74/10 CTE

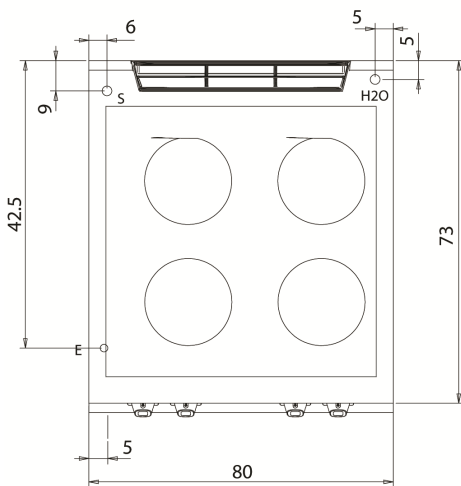
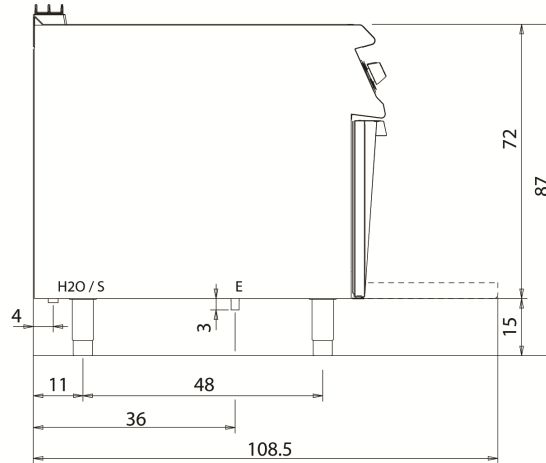
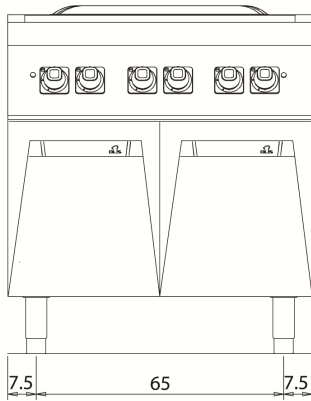

KEY

- E power supply
- G gas connection
- H20 water inlet
- S water outlet

Connection	Power	Diameter	Supply
Gas connecton			
Electric connecton	10	400	
Cold water connecton			0
Hot water connecton			
Cold soft water connecton			
Drain (∅)			
2° Drain (∅)			