



*we*innovate cooking

KITCHENS DIAMANTE 70

BOILING PANS

Model

D73/10PEI05

Code

CR0990179

General characteristics

- Stainless steel outer coatings and feet.
- Worktops made of 1,5 mm thick, brushed AISI 304 stainless steel.
- Adjustable worktop height from 840 to 900 mm.
- Contoured control panels with controls tilted towards the operator.
- Large knobs that do not protrude from the machine structure.
- Range modularity: 200-400-600-800-1200.
- Simple and effective coupling system.
- Appliances set up for the plinth.
- Vast accessory range.
- Appliances in compliance with CE standards.

ELECTRIC BOILING PAN 50 LT. INDIRECT HEATING



Technical/functional characteristics

- Outer casing and feet in stainless steel.
- Adjustable worktop height, ranging from 840 to 900 mm.
- Adjustable worktop height, ranging from 840 to 900 mm.
- AISI 304 stainless steel pan with base in AISI 316 stainless steel.
- Water loading using the tap and both hot or cold water may be loaded.
- Front discharge with 2-inch chrome brass taps.
- 2 armoured heater units mounted inside the cavity for heating operations.

Technical Data

Model	D73/10PEI05
Width (mm)	600,00
Depth (mm)	730,00
Height (mm)	870,00
VOLUME	522.730,00
WEIGHT	0,00
SUPPLY	
Gas power	
Electric power	9.8
Internal ovens dimension	
OVEN CAPACITY	
Plate dimensions (mm)	
TANK DIMENSIONS	
Tank capacity (l)	

BOILING PANS

Model
D73/10PEI05

Code
CR0990179

D73/10 PEI05

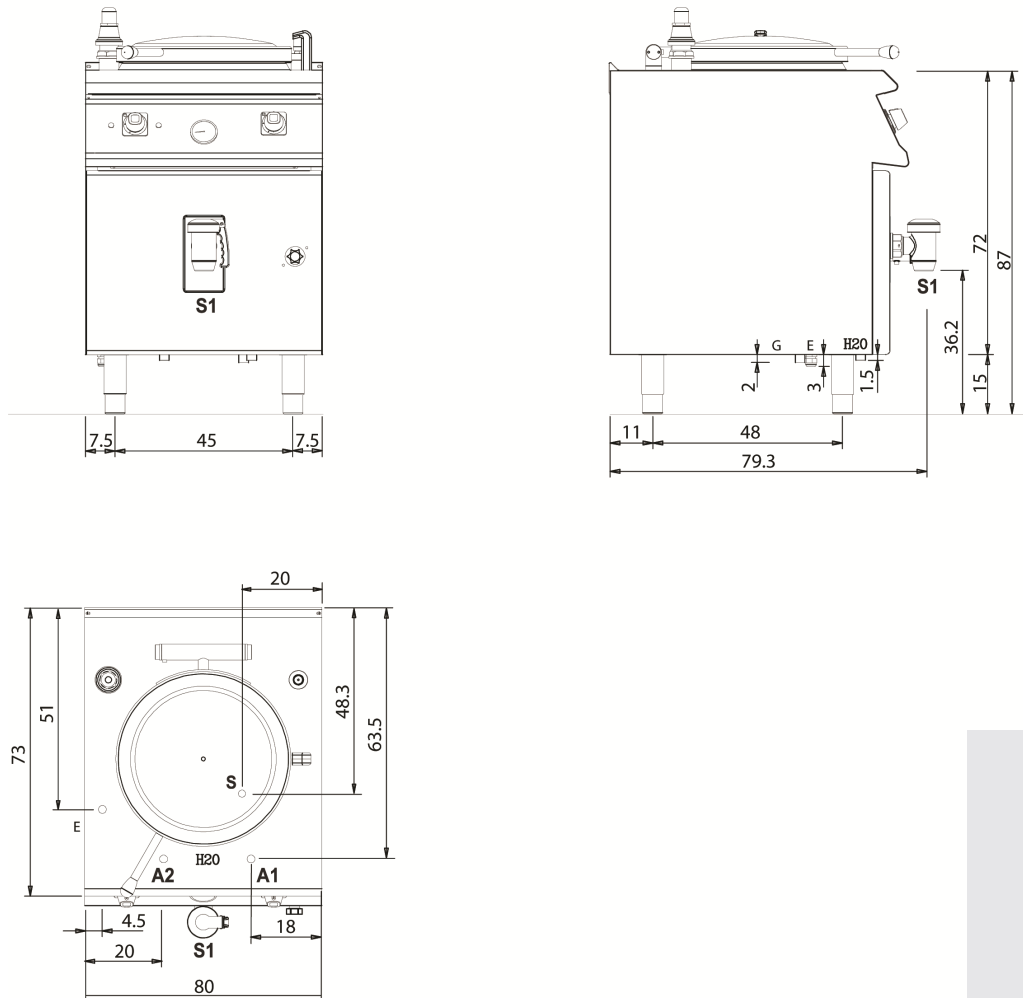

KEY

- E power supply
- G gas connection
- H20 water inlet
- S water outlet

Connection	Power	Diameter	Supply
Gas connecton			
Electric connecton	9.8	400	
Cold water connecton		3/4"	0
Hot water connecton		3/4"	
Cold soft water connecton			
Drain (∅)		1"	
2° Drain (∅)			