



*we*innovate cooking

# KITCHENS

## 650 SERIE

### GAS GRIDDLE PLATES

Model

OFT64GLC

Code

CR0854109

#### General characteristics

The SNACK 650 range by OLIS has been created with a distinctive design for all its equipment, both in the top and single-unit version, with large knobs and an ergonomic shape for the control panels. The wide selection of machines and their high performance make this range the ideal choice for rooms with a limited amount of space that still need efficient machines. The range's modularity allows for endless combinations with installations placed on cabinet bases or tables.

#### GAS GRIDDLE PLATE - CHROMIUM SMOOTH PLATE



#### Technical/functional characteristics

The steel cooking plates are heated by gas burners, so as to guarantee that the temperature will rise rapidly and maintain the preselected values. The temperature can be adjusted from 120-280°C. The plates are equipped with splash guards so that the hob can be kept perfectly clean and hygienic. The work surface is slightly sloped so as to send sauces, grease and dressings into the capacious drip tray designed for this purpose. Designed with piezoelectric ignition, pilot flame, thermocouple and valved tap to ensure maximum safety. Chromed models are equipped with thermostatic temperature control, a safety thermostat and power lights.

#### Technical Data

Model OFT64GLC

Width (mm) 400,00

Depth (mm) 650,00

Height (mm) 295,00

VOLUME 0,15

WEIGHT 38,00

SUPPLY GAS

Gas power 5

Electric power

Internal ovens dimension

OVEN CAPACITY

Plate dimensions (mm) 396x555

TANK DIMENSIONS

Tank capacity (l)

### GAS GRIDDLE PLATES

Model  
OFT64GLC

Code  
CR0854109

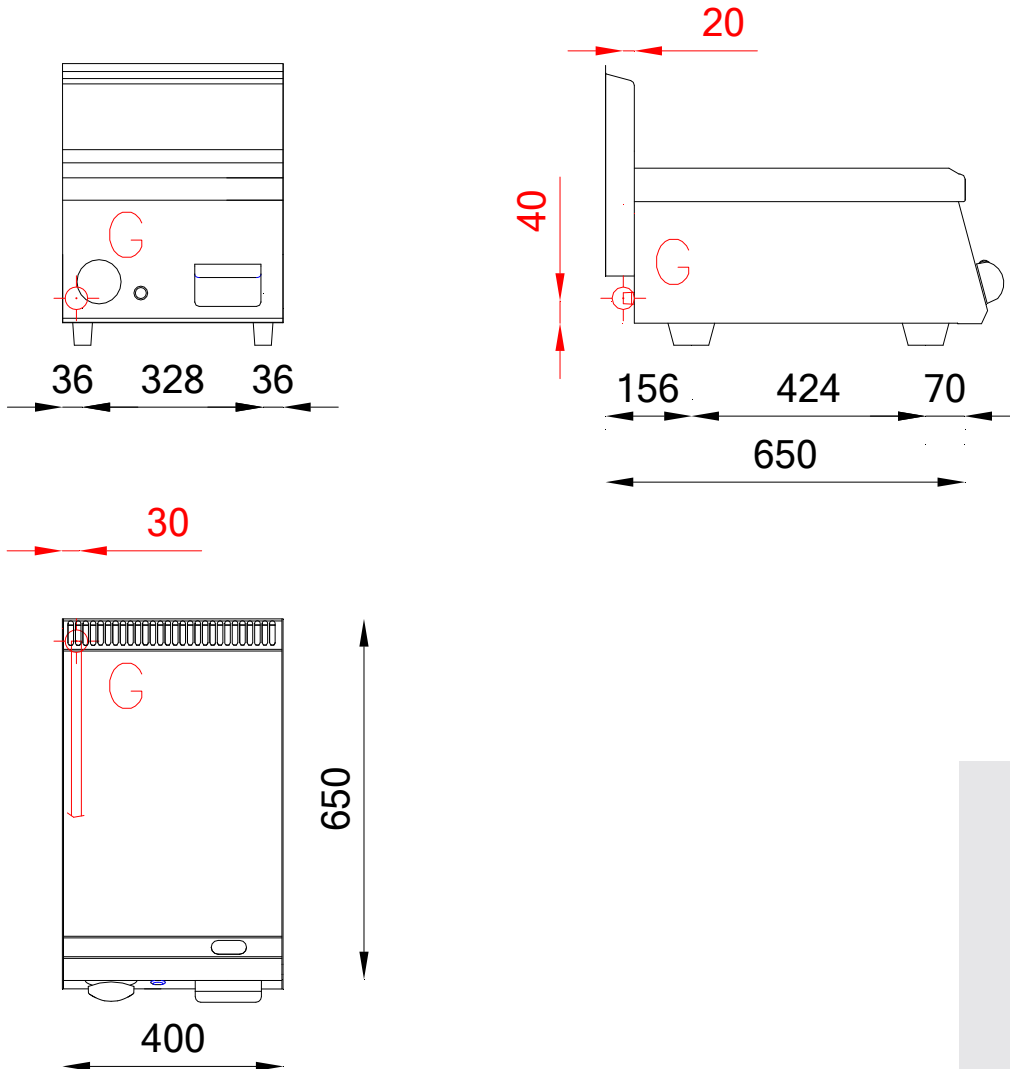

#### KEY

- E power supply
- G gas connection
- H2O water inlet
- S water outlet

Connection	Power	Diameter	Supply
Gas connecton	5	1/2"	
Electric connecton			
Cold water connecton			
Hot water connecton			
Cold soft water connecton			
Drain (∅)			
2° Drain (∅)			