



weinnovate cooking

KITCHENS DIAMANTE 90

WOK GAS

Model

D95/10CGW28

Code

CR0991809

General characteristics

- Stainless steel outer coatings and feet.
- Worktops made of 2 mm thick, brushed AISI 304 stainless steel.
- Adjustable worktop height from 840 to 900 mm.
- Contoured control panels with controls tilted towards the operator.
- Large knobs that do not protrude from the machine structure.
- Range modularity: 200-400-600-800-1200.
- Simple and effective coupling system.
- Appliances set up for the plinth.
- Vast accessory range.
- Appliances in compliance with CE standards.

WOK 2 BURNER GAS RANGE 14KW ON OPEN CUPBOARD



Technical/functional characteristics

- Outer casing and feet made of AISI 304 steel.
- Worktops with a 20/10 thickness with 550x720 mm recess or 950x720 mm.
- Right rear drain with a 22 mm diameter, configured for earth connection.
- With grease collection draw (approx. 2/3 lt capacity).

Technical Data

Model	D95/10CGW28
Width (mm)	1.000,00
Depth (mm)	900,00
Height (mm)	870,00
VOLUME	0,78
WEIGHT	0,00
SUPPLY	
Gas power	28
Electric power	
Internal ovens dimension	
OVEN CAPACITY	
Plate dimensions (mm)	
TANK DIMENSIONS	
Tank capacity (l)	

WOK GAS

Model
D95/10CGW28

Code
CR0991809

D95/10CGW28

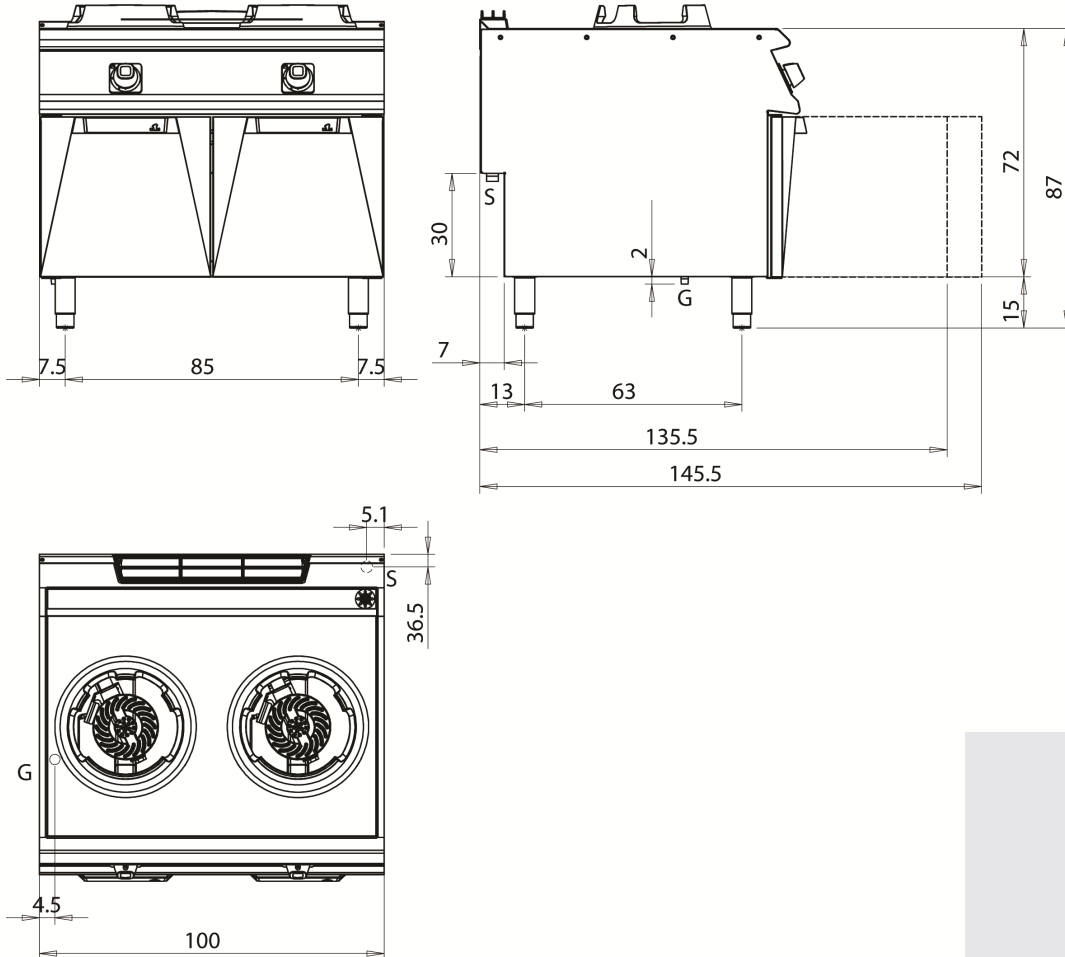

KEY

- E power supply
- G gas connection
- H2O water inlet
- S water outlet

Connection	Power	Diameter	Supply
Gas connecton	28	1/2"	
Electric connecton			
Cold water connecton			
Hot water connecton			
Cold soft water connecton			
Drain (Ø)			
2° Drain (Ø)			