

RF Amplifiers

Tactical Booster, Rack Mount, Modules

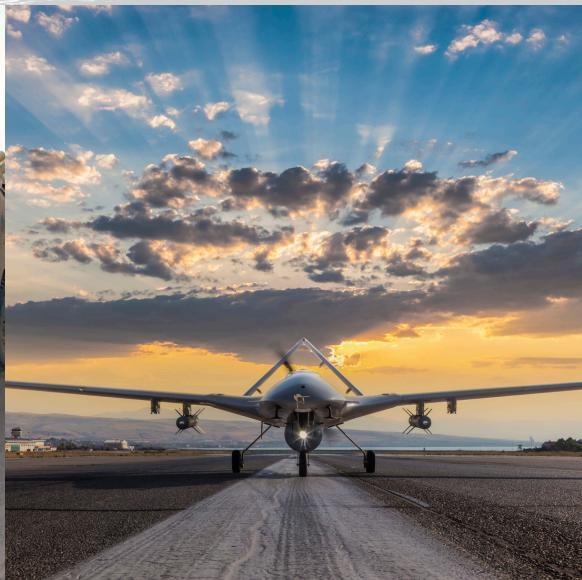

Vehicle, Airborne, Manpack, Shipboard, Communications, ISM



Communication Links...Enhanced.

Tactical Booster Amplifiers, RF Systems, and Modules that meet the toughest challenges.

The Ametek PDS Amplifier product line plays a critical role in wireless and radio communications, military communications networks, electronic warfare, electronic countermeasures, and homeland security. Our amplifier product line also has a variety of industrial, scientific, and medical applications.

- RF amplifier modules: 80 kHz -3,000 MHz, 5 to 500 watts
 - Broadband, narrowband, and custom designs available
- Rack-mount amplifier systems: 80 kHz -3,000 MHz, 5 to 1,000 watts
- Booster amplifiers for tactical military radios from 30 MHz to 3 GHz, 20 -125 watts
- Power amplifiers for legacy communication waveforms as well as virtually every new and emerging communications system



Ahead of the Wave

As experienced specialists in amplifiers, Ametek PDS leads the next generation of technology development to deliver mission-critical solutions.

As market leaders, we recognize the critical elements that drive performance, dependability, and ease of operation. Our amplifiers are radio agnostic turnkey solutions that maintain minimum operator interface and superior performance while not compromising on size, weight, or power requirements. Our customers are some of the most demanding in the world as we support deployments in all branches of the military on the ground, air, sea, and SOF community.

Ametek PDS continues to pass the toughest tests in the most extreme environments with designs that stay ahead of the newest industry requirements.



AR-75



Airborne Applications

Airborne Certified, Gunship Approved

The booster amplifiers specified for these aircraft are the most reliable, easiest-to-use, long range, and innovative booster amplifiers available today.

- Reliable
- Sophisticated
- In-use
- Proven
- Lightweight
- Battle tested



AR-20H



AR-50

Our products have been tested and certified for military airborne applications like these, plus many more!



MC-12 Liberty
AR-50



Unmanned Aerial Vehicle
AR-20H



AW189
AR-50



EC-130J
AR-35 / AR-75



MH-60M Blackhawk
AR-20H



CV-22 Osprey
AR-50



MH/AH-6M Little Bird
AR-20H



MH-47G Chinook
AR-20H



Built to Perform

Rugged, reliable performance with minimum operator intervention comes through innovative technology, advanced design, and superior workmanship. Tactical Booster Amps offer automatic T/R Switching, Harmonic Filtering, and Overtemp Protection. Proven in deployments worldwide, our amps have been proven themselves in Vehicle, Fixed and Rotary Aircraft, Manpack, Drop Kit, and Shipboard applications.

Waveforms Supported:

- ANW2, IW, SRW, WNW, ASCM, SINCGARS, HAVEQUICK I and II, TSM, WREN, Katana, plus others!

Frequency Bands Supported:

- HF/VHF/UHF/L-Band/S-Band

Supports Multiple Radio Platforms:

- AN/PRC-154 Rifleman™ Radio
- AN/PRC-117, AN/PRC-117G
- AN/PRC-152, AN/PRC-148 (MBITR/JEM)
- AN/PSC-5D, AN/ARC-210
- AN/PRC-163, AN/PRC-167, plus others!

AR-20H Airborne Flight Certified

- 20 Watts
- 30–512 MHz
- Lighter package
- Lower profile
- Supports legacy and modern networking waveforms
- MIL-STD 810G (Including Gunship)
- MIL-STD 461F, MIL-STD 464C, MIL-STD



AR-20

- 20 Watts
- 30–512 MHz
- Lighter package
- Lower profile
- Internal LNA
- Co-site filtering
- Supports legacy and modern networking waveforms



AR-FS-20

- 20 Watts
- 225–450 / 1250-2600 MHz
- Fast T/R switching - under 2 μ s
- ITN Manet waveform support
- Integrated LNA
- Fully automatic
- Radio Agnostic



AR-50S

- 50 Watts
- 30–88 MHz
- SINCGARS compatible
- Compatible with Thales PRC-148, Harris PRC-152, Harris PRC-117F, Harris PRC-117G, and others



AR-50SE

- 50 Watts
- 30–88 MHz
- SINCGARS compatible
- DC ON/OFF switch
- Full band high-speed filter switching to ensure interference free operation



AR-50

- 50 Watts
- 30–512 MHz
- Internal LNA
- Supports legacy and modern networking waveforms
- DAMA and IW Certified
- 810G (including SB-X10001B)
- Compatible with Thales PRC-148, Harris PRC-152, Harris PRC-117F, Harris PRC-117G, and others



AR-75

- 75 Watts
- 30–512 MHz
- Compatible with Harris PRC-117F, Harris PRC-117G, and others
- Includes MIL-STD 461/1275 filter
- Supports legacy and modern networking waveforms
- Airborne Safety Flight Certified



Tactical Booster Amplifiers





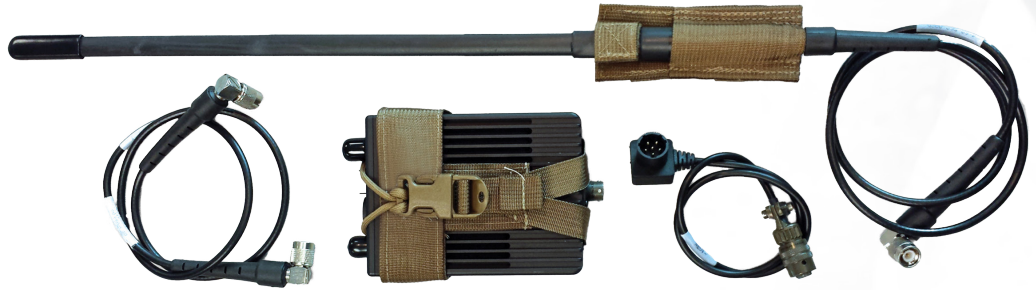





MODEL NAME	DESCRIPTION
AR-20	20 Watts PEP, 30–512 MHz, Tx/Rx Booster Amplifier with LNA
AR-20KT	20 Watts PEP, 30–512 MHz, Tx/Rx Booster Amplifier Kit with LNA. Kit includes amplifier, cables, pouches and LOS antenna
AR-20B	20 Watts PEP, 30–512 MHz, Tx/Rx Booster Amplifier
AR-20BKT	20 Watts PEP, 30–512 MHz, Tx/Rx Booster Amplifier Kit. Kit includes Amplifier, Cables, Pouches and LOS Antenna
AR-20H	20 Watts PEP, 30–512 MHz, Tx/Rx Booster Amplifier with Remote Keyline
AR-20HC2	20 Watts PEP, 300–512 MHz, Tx/Rx Booster Amplifier
AR-35	35 Watts PEP, 30–512 MHz, Tx/Rx Booster Amplifier
AR-50	50 Watts PEP, 30–512 MHz, Tx/Rx Booster Amplifier
AR-50C2	50 Watts PEP, 30–512 MHz, Tx/Rx Booster Amplifier, High Input Power
AR-50M	50 Watts PEP, 30–512 MHz, Tx/Rx Booster Amplifier, Configured for MUOS
AR-50RC	25 Watts PEP, 30–512 MHz / 50 Watts PEP 290–320 MHz, RF Tx/Rx Booster Amplifier
AR-50S	50 Watts PEP, 30–88 MHz, Tx/Rx Booster Amplifier
AR-50-SAT75	50 Watts PEP, 30–512 MHz / 75 watts PEP 220–324 MHz, Tx/Rx Booster Amplifier
AR-50SE	50 Watts PEP, 30–88 MHz, Tx/Rx Booster Amplifier
AR-75	75 Watts PEP, 30–512 MHz, Tx/Rx Booster Amplifier



AR-20BKT



Features	AR-20	AR-20KT	AR-20B	AR-20BKT	AR-20H	AR-20CH2	AR-35	AR-50	AR-50C2
									
Power Output	20 Watts CW 20 Watts PEP	20 Watts CW 20 Watts PEP	20 Watts CW 20 Watts PEP	20 Watts CW 20 Watts PEP	20 Watts CW 20 Watts PEP	20 Watts CW 20 Watts PEP	35 Watts CW nominal 20 Watts PEP with 70% AM Modulation	50 Watts CW nominal; 50W PEP with 70% AM modulation, ,10% distortion typical	50 Watts CW, 50 Watts PEP with 80% AM modulation, <10% distortion typical
Frequency Range	30 MHz-512 MHz	30 MHz-512 MHz	30 MHz-512 MHz	30 MHz-512 MHz	30 MHz-512 MHz	300 MHz-500 MHz	30 MHz-512 MHz	30 MHz-512 MHz	30 MHz-512 MHz
Input Power	2W CW or PEP for full 20W Output	2W CW or PEP for full 20W Output	2W CW or PEP for full 20W Output	2W CW or PEP for full 20W Output	Nominal 2W-5W CW or PEP for full 20W Output	Nominal 0.75W-3W CW or PEP for full 20W Output	3W PEP typical for 35W PEP Output	<5W CW typical for 50W Output	<5W CW typical for 50W Output
SATCOM Rx LNA	Built-in	Built-in	N/A	N/A	Built-in	Built-in	N/A	Built-in	Built-in
SATCOM RX LNA Gain / Noise Figure	12 dB/<2.5 dB typical	12 dB/<2.5 dB typical	N/A	N/A	6 dB / 4 dB typical	10 dB / 2.5 dB typical	N/A	12 dB / 2.5 dB typical	12 dB / 2.5 dB typical
SATCom RX Co-site Filter	Co-site filter provides >35 dB protection to the SATCOM receive channels	Co-site filter provides >35 dB protection to the SATCOM receive channels	N/A	N/A	N/A	N/A	N/A	Band pass frequency 239 - 273 MHz, Out of band rejection >45 dB typical	Band pass frequency 239 - 273 MHz, Out of band rejection >35 dB typical
Modulation	All legacy and modern complex tactical communications waveforms like ANW2, IW and SRW	All legacy and modern complex tactical communications waveforms like ANW2, IW and SRW	All legacy and modern complex tactical communications waveforms like ANW2, IW and SRW	All legacy and modern complex tactical communications waveforms like ANW2, IW and SRW	All legacy and modern complex tactical communications waveforms like ANW2, IW and SRW	All legacy and modern complex tactical communications waveforms like FSK, ANW2, IW and SRW	AM, FM, or PM, and tactical communications waveforms	All legacy and modern complex tactical communications waveforms like ANW2, IW and SRW	All legacy and modern complex tactical communications waveforms like ANW2, IW and SRW
Power Requirements	12-35.5 VDC single XX90 battery or 12 and 28 VDC vehicle supply	12-35.5 VDC single XX90 battery or 12 and 28 VDC vehicle supply	12-35.5 VDC single XX90 battery or 12 and 28 VDC vehicle supply	12-35.5 VDC single XX90 battery or 12 and 28 VDC vehicle supply	18-35.5 VDC compliant to MIL-STD 704F, MIL-STD 461F, MIL-STD 464C	9.5 to 36 VDC	13.8 VDC from two XX90 batteries or 12 and 24 VDC vehicle systems, filtered and transient protected	12-36 VDC from battery or 12 and 24 VDC vehicle systems, filtered and transient protected	12-35.5 VDC from two XX90 batteries or 12 and 24 VDC vehicle systems, filtered and transient protected
Current @ 24 VDC nominal	<3.2A @ 28 V typical	<3.2A @ 28 V typical	<3.2A @ 28 V typical	<3.2A @ 28 V typical	<3.2A @ 24 V typical	<3.5A @ 24 V typical	5.5A nominal	7.5A nominal	7.5A nominal
Operating Temperature	-30 to 60° C ambient	-30 to 60° C ambient	-30 to 60° C ambient	-30 to 60° C ambient	-40 to 71° C ambient	-40 to 70° C ambient	-30 to 60° C ambient	-30 to 60° C ambient	-30 to 60° C ambient
Water	IP67	IP67	IP67	IP67	IP67	IP67	66 ft for 20 min	IP67	IP67
Vibration / Shock / Humidity	Designed to meet applicable sections of MIL-STD-810 / designed for ground / base vehicle use	Designed to meet applicable sections of MIL-STD-810 / designed for ground / base vehicle use	Designed to meet applicable sections of MIL-STD-810 / designed for ground / base vehicle use	Designed to meet applicable sections of MIL-STD-810 / designed for ground / base vehicle use	MIL-STD-810G	MIL-STD-810	MIL-STD-810F / Hand portable	MIL-STD-810G (Including SB-X 10001B)	MIL-STD-810F
Size (HxWxD) Inches	1.58 x 3.75 x 5.05	1.58 x 3.75 x 5.05	1.58 x 3.75 x 5.05	1.58 x 3.75 x 5.05	1.86 x 3.75 x 8.78	1.86 x 3.75 x 8.87	2.30 x 3.00 x 7.70	2.50 x 6.00 x 7.50	2.50 x 6.00 x 7.50
Weight	1 lb. 10 oz	2 lb. 15 oz (full kit)	1 lb. 10 oz	2 lb. 15 oz (full kit)	2.6 lb.	2.6 lb.	2 lb.	4.4 lb.	4.4 lb.
JITC Certified	Yes	Yes	No	No	No	No	No	PSC-5D, PRC-117G, PRC-148 JEM	PSC-5D, PRC-117G, PRC-148 JEM
GSA Schedule	Yes	Yes	Yes	Yes	Yes	Yes	Yes	Yes	Yes

Features

AR-50M

AR-50RC

AR-50S

AR-50SE

AR-50SAT75

AR-75

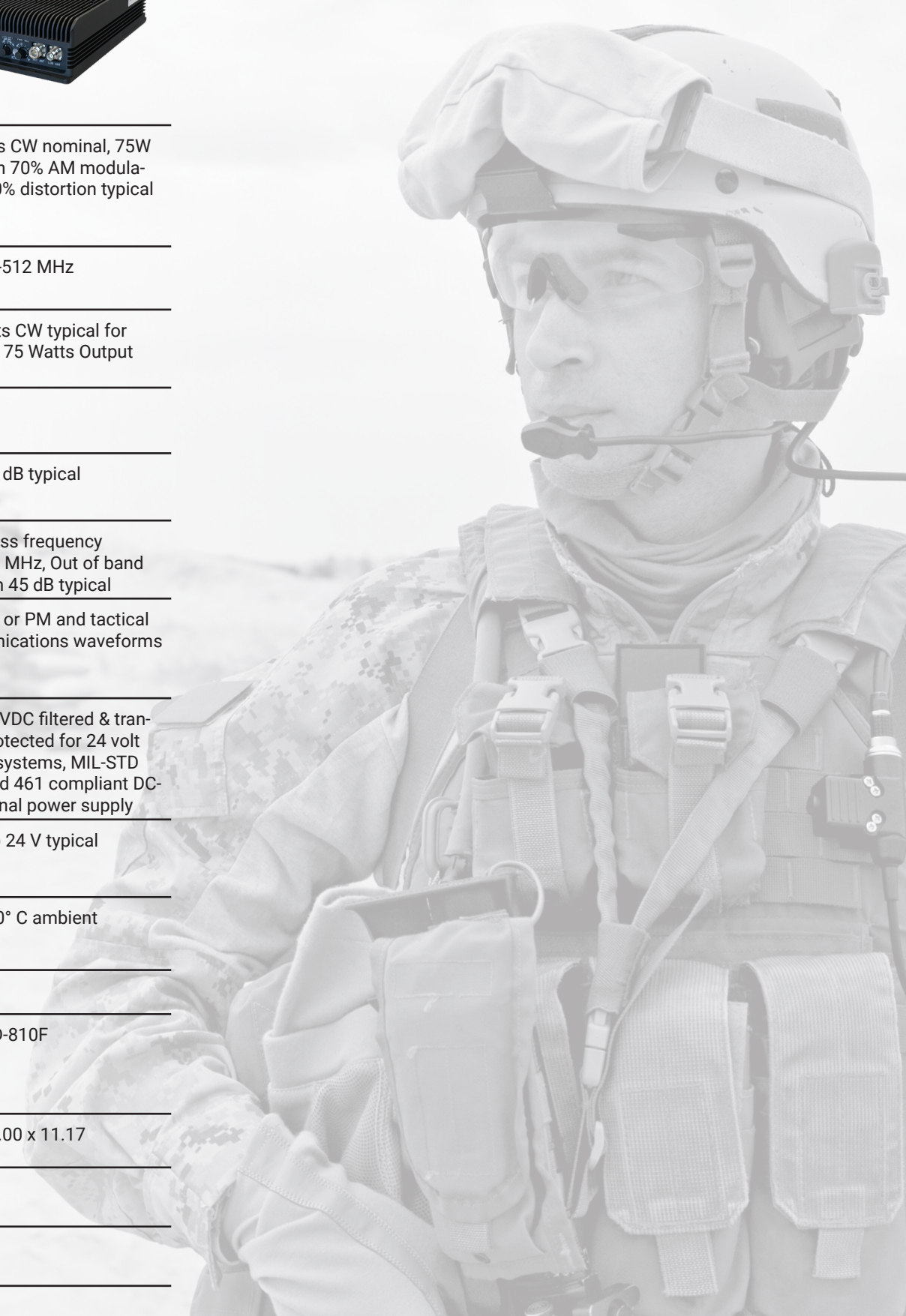

Power Output	50 Watts CW, 50 Watts PEP with 80% AM modulation, <10% distortion typical	LOS: 25 Watts nominal, 25W PEP with 70% AM modulation, <10% distortion typical SATCOM (290 MHz to 320 MHz): 50 Watts	50 Watts CW nominal, 50W PEP with 80% AM modulation, <10% distortion typical	50 Watts CW nominal, 50W PEP with 80% AM modulation, <10% distortion typical	LOS: 50 Watts SATCOM: 75 Watts	75 Watts CW nominal, 75W PEP with 70% AM modulation, <10% distortion typical
Frequency Range	30 MHz-512 MHz	30 MHz-512 MHz	30 MHz-88 MHz	30 MHz-88 MHz	LOS: 30 MHz-512 MHz SATCOM: 220-324 MHz	30 MHz-512 MHz
Input Power	<5W CW typical for 50W Output	<5 Watts CW typical for 25W LOS and 30W SATCOM Output	<5 Watts CW typical for 50 watts Output	<5 Watts CW typical for 50 watts Output	LOS: 4-6 Watts SATCOM: 7-8 watts	5-8 Watts CW typical for nominal 75 Watts Output
SATCOM Rx LNA	Built-in	Built-in	N/A	N/A	Built-in	Built-in
SATCOM RX LNA Gain / Noise Figure	12 dB/<2.5 dB typical	12 dB/<2 dB typical	N/A	N/A	12 dB/2 dB typical	12 dB/2 dB typical
SATCom RX Co-site Filter	Band pass frequency 239 - 273 MHz, Out of band rejection >35 dB typical	Band pass frequency 239 MHz-273 MHz, Out of band rejection 35 dB typical	N/A	N/A	Band pass frequency 329-270 MHz, Out of band rejection 55 dB typical	Band pass frequency 239-273 MHz, Out of band rejection 45 dB typical
Modulation	All legacy and modern complex tactical communications waveforms like ANW2, IW and SRW	AM, FM, or PM and tactical communications waveforms	AM, FM, or PM and tactical communications waveforms	AM, FM, or PM and tactical communications waveforms	AM, FM, or PM and tactical communications waveforms	AM, FM, or PM and tactical communications waveforms
Power Requirements	12-35.5 VDC from two XX90 batteries or 12 and 24 VDC vehicle systems, filtered and transient protected	12-35.5 VDC filtered and transient protected for 12 to 24 volt vehicle systems or dual XX90 batteries	12-36 VDC filtered and transient protected for 12 or 24 Volt vehicle systems or dual XX90 batteries	12-33 VDC MIL-STD-461E and 1275	18-35.5 VDC filtered and transient protected for 24 volt vehicle systems or dual XX90 batteries	18-35.5 VDC filtered & transient protected for 24 volt vehicle systems, MIL-STD 1275 and 461 compliant DC-DC internal power supply
Current @ 24 VDC nominal	7.5A nominal	<7.5A @ 24 V typical	<7.5A @ 24 V typical	<7.5A @ 24 V typical	<8.5A @ 24 V typical (75 W SATCOM)	<9.5A @ 24 V typical
Operating Temperature	-30 to 60° C ambient	-30 to 60° C ambient	-30 to 60° C ambient	-40 to 55° C ambient	-30 to 60° C ambient	-30 to 60° C ambient
Water	IP67	IP67	IP67	IP67	IP67	IP67
Vibration / Shock / Humidity	Designed to meet applicable sections of MIL-STD-810 / designed for ground / base vehicle use	Per MIL-STD-810F	Per MIL-STD-810F	Per MIL-STD-810F	Designed to meet applicable sections of MIL-STD-810F/ designed for ground / base vehicle use	MIL-STD-810F
Size (HxWxD) Inches	2.50 x 6.00 x 7.50	2.50 x 6.00 x 7.50	2.50 x 6.00 x 7.50	2.50 x 6.50 x 9.93	3.25 x 5.25 x 7.50	3.00 x 6.00 x 11.17
Weight	4.4 lb.	4.4 lb.	4.4 lb.	8.0 lb.	4.9 lb.	10.5 lb.
JITC Certified	Based off AR-50 design	Based off AR-50 design	Based off AR-50 design	Based off AR-50 design	Based off AR-50 design	No
GSA Schedule	Yes	Yes	Yes	Yes	Yes	Yes

The Right Amplifier for Your System

Rack Mount and Module Amplifiers

Finding the best amplifier for your application is easy with our full line of Rack Mount and Module Amplifiers. These units are well-suited for ISM and OEM customers.

Known for their superior quality and reliability, the amps operate from 80 kHz to 3,000 MHz while providing up to 1 kW Output Power. Our amplifiers are customizable for Operating Bandwidth, Power, and Gain to deliver the solution to meet system requirements.

The AR-5000 series is built on a common 19" rack platform to give full control and monitoring while easily customizing the RF deck to meet customer specific needs. Controls and interfaces include Touch Screen, Ethernet, RS-232, RF Gain, Blanking, Temp Monitoring, etc.

Contact our team for help deciding the right amp for your application.



- AR-5020**
The Next Generation of Wideband
- Class A or Class AB
 - Lightweight 19-in., 2U rack mount
 - Ethernet remote control
 - 100–150 Watts CW PEP
 - 118 MHz to 400 MHz 704F



- AR-5030 / AR-5030C2**
Shipboard Communications
- Lightweight, 19-in., 2U Rack Mount
 - Ethernet remote control
 - 80 Watts CW/PEP
 - 700 MHz to 960 MHz

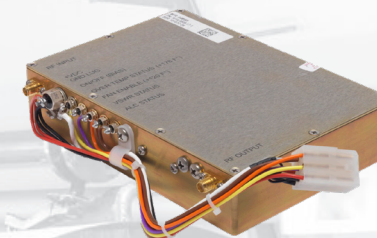

- Subsystems for Integration**
- Custom packaging
 - Engineered to customer specifications
 - Sub-octave and multi-octave designs



- Modules for OEMs and Integration**
- 10 kHz to 5 GHz
 - High- and low-gain power amplifier modules
 - Mini-system PA modules with ALC and interfaces



- AR-5000**
Base Platform for Quick Customizations
- Class A or Class AB
 - Lightweight 19-in., 2U rack mount
 - Ethernet remote control
 - 100–500 Watts CW, 1,000 Watts peak
 - 80 kHz to 1 GHz
 - 30 MHz to 88 MHz 704F



- AR-5010**
Basic Communications
- Lightweight, 19-in., 2U rack mount
 - Ethernet remote control
 - 500 Watts CW/PEP
 - 30 MHz to 88 MHz 704F



- Communications Systems**
- VHF/UHF band operation
 - Up to 1,000 Watt output
 - 24/7 operation capable
 - Repeatable performance unit to unit for field interchangeability
 - Single-phase and three-phase AC power capable from same unit

Amplifier Modules

Model Name	Description
AIRWALK MOUS	300 - 320, 360 - 380 MHz, 100W (Peak)
KMA1001	1 Watt, 225 - 400 MHz, Amplifier Module
KMA1040	50 Watts, 200 KHz - 50 MHz, Amplifier Module
KMA1040-M1	50 Watts, 200 KHz - 50 MHz, Amplifier Module with Heat Sink
KMA2020	100 Watts, 10 kHz - 230 MHz, Amplifier Module
KMA2020-M1	100 Watts, 10 kHz - 230 MHz, Amplifier Module with Heat Sink
KMA2040	200 Watts, 500 kHz - 40 MHz, Amplifier Module
KMA2040-M1	200 Watts, 500 kHz - 40 MHz, Amplifier Module with Heat Sink
KMA2040-M15	200 Watts CW, 1 - 25 MHz, Amplifier Module, (RoHS)
KMA2040-M22	200 Watts CW, 250 Watts Peak, 2 - 30 MHz, Amplifier Module
KMA2040-M25C1	100 - 500 Watts, 100 KHz - 50 MHz, Amplifier Module, RF IN / RF OUT connectors on the side
KMA2040T	200 Watts CW/PEP, 4.4 to 44 MHz, Amplifier Module
KMW1020	10 Watts, 500 kHz - 512 MHz, Amplifier Module
KMW1020-M1	10 Watts, 500 kHz - 512 MHz, Amplifier Module with Heat Sink
KMW1060	20 Watts, 1 - 512 MHz, Amplifier Module
KMW1060-M1	20 Watts, 1 - 512 MHz, Amplifier Module with Heat Sink
KMW2025	100 - 200 Watts CW, 500 Watts Pulse, 30 - 512 MHz, Amplifier Module
KMW2026-M15	40 Watts, 225 - 450 MHz, Amplifier Module
KWW2026-M20	100 - 200 Watts, 30 - 512 MHz Amplifier Module with Break Point
KMW2026-M26	60 Watts, 291 MHz, Amplifier Module
KMW2040	100 Watts CW, 100 - 500 MHz, Amplifier Module
KMW2040-LTE	100 Watts CW/125 Watts Peak, 225 - 400 MHz, Amplifier Module
KMW2040-M1	100 Watts CW, 100 - 500 MHz, Amplifier Module with Heat Sink
KMW3434	30 Watts CW, 400 - 450 MHz Amplifier Module

Rack Mount Amplifiers

Model Name	Description
AR-5000	19" Rack Mount Product Series. 100-500 Watts, 80 MHz-1,000 MHz
AR-5010	500 watts CW/PEP, 30-88 MHz, 2U/3U 19" Rack Mount, Ethernet Remote Control, Power Monitor and Blanking
AR-5020	125 Watts CW/PEP, 118 to 144 MHz, 225 to 400 MHz 19" Rack Mount
AR-5030	80 Watts CW/PEP, 700 to 960 MHz, 2U/3U 19" Rack Mount, Ethernet Remote Control, Power Monitoring and Blanking
AR-5030C2	80 Watts CW/PEP, 700 to 960 MHz, 19" Rack Mount
KAA2026	125 Watts, 700 kHz-3 MHz, RF Amplifier, 19" Rack Mount
KAA2030	200 Watts, 500 kHz - 40 MHz, RF Amplifier
KAA4020	500 Watts, 1 - 50 MHz, RF Amplifier, 19" Rack Mount
KAA4020-M1	500 Watts, 1 - 50 MHz, RF Amplifier, 19" Rack Mount
KAA4021P	300 Watts, Pulse, 1 - 50 MHz, RF Amplifier, 19" Rack Mount
KAA5170P	1000 Watts, Pulse, 500 kHz - 5.5 MHz, RF Amplifier, 19" Rack Mount
KAW1020	5 Watts, 500 kHz-1,000 MHz RF Amplifier
KAW1040	20 Watts, 1 MHz-512 MHz, RF Amplifier
KAW1040-M1	50 Watts, 200 KHz - 50 MHz, RF Amplifier, 19" Rack Mount
KAW1050	25 Watts, 1 MHz-400 MHz, RF Amplifier
KAW1080	25 Watts, 10 kHz - 1000 MHz, Dual Band RF Amplifier, 19" Rack Mt
KAW2300	100 Watts PEP, 100 MHz-1,000 MHz, RF Amplifier, 19" Rack Mt
KAW4040-M12	500 Watts, 390 - 410 MHz, RF Amplifier, 19" Rack Mount
KAW5030	200 Watts, 800 watts Peak, 100 MHz-400 MHz, RF, 19" RM



AMETEK PDS / Abaco

- Binghamton, NY
- Bothell, WA
- Harleysville, PA
- Wichita, KS
- Bangalore, India
- Reynosa, Mexico

AmetekPDS.com

ametek-pds-sales@ametek.com

