

Seal housing

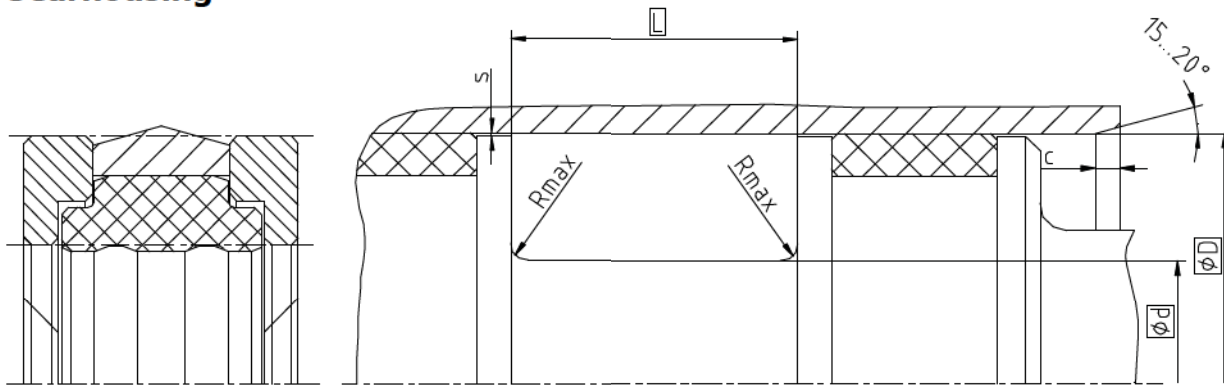

Surface roughness	Rtmax	Ra
Sliding Surface	≤ 2,5 μm	0,1...0,5 μm
Bottom of groove	≤ 6,3 μm	≤ 1,6 μm
Groove face	≤ 15 μm	≤ 3 μm

Ordering dimensions...□

Bearing area: 50...95% and a cutting depth of 0,5xRz based on Cref = 0%

Standard dimensions

ØD H9	Ød h9	L +0,2	Rmax	c	s*
≥ 20 ... < 50	D - 10	12,5	0,4	4	0,4
≥ 50 ... < 80	D - 15	20		5	
≥ 80 ... < 150	D - 20	25		6	
≥ 150 ... < 400	D - 25	32		8,5	
≥ 400 ... < 600	D - 30	36		10	

* Extrusion gap applies to a temperature of 70 °C, higher temperatures require lower values.

Operating parameters

Sealing material	Energizer	Backup ring	Temperature	max. speed	max. pressure ¹
ECOPUR®	SKF ECORUBBER-1	SKF ECOTAL SKF ECOMID ²	-30 °C...+100 °C	0,3 m/s	1500 bar (150 MPa)
H-ECOPUR™			-20 °C...+100 °C		
S-ECOPUR™			-40 °C...+100 °C	0,4 m/s	
T-ECOPUR™	SKF ECOSIL		0,3 m/s		

The stated operation conditions represent general indications. It is recommended not to use all maximum values simultaneously. Surface speed limits apply only to the presence of adequate lubrication film.

¹ Pressure ratings depend on the size of the extrusion gap.

² ≤ Ø260mm: SKF ECOTAL ; > Ø260mm: SKF ECOMID

Ordering example

K23-H, D=100mm, d=80mm, L=25mm, ECOPUR® / SKF ECORUBBER-1 / SKF ECOTAL

Piston Seal K23-H 100 x 80 x 25 ECOPUR® / SKF ECORUBBER-1 / SKF ECOTAL

Profile

D x d x L

Sealing material / Energizer / Backup ring