

# Seal data sheet

## Piston seals

### Seal housing

K23-F



2008-09

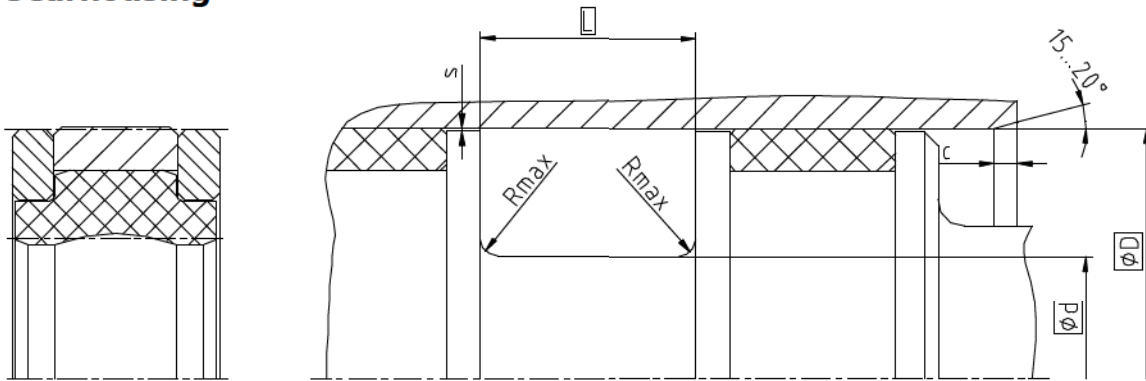

Surface roughness	Rtmax	Ra
Sliding Surface	≤ 2 µm	0,05...0,3 µm
Bottom of groove	≤ 6,3 µm	≤ 1,6 µm
Groove face	≤ 15 µm	≤ 3 µm

Ordering dimensions...□

Bearing area: 50...95% and a cutting depth of 0,5xRz based on Cref = 0%

### Standard dimensions

ØD H9	Ød h9	L +0,2	Rmax	c	s*
≥ 20 ... < 50	D - 10	12,5	0,4	4	0,4
≥ 50 ... < 80	D - 15	20		5	
≥ 80 ... < 150	D - 20	25		6	
≥ 150 ... < 400	D - 25	32		8,5	
≥ 400 ... ≤ 750	D - 30	36		10	
> 750	D - 40	40		13	

\* Extrusion gap applies to a temperature of 70 °C, higher temperatures require lower values.

### Operating parameters

Sealing material	Energizer	Backup ring	Temperature	max. speed	max. pressure <sup>1</sup>
X-ECOPUR™	SKF ECORUBBER-1	SKF ECOTAL SKF ECOMID <sup>2</sup>	-30 °C...+100 °C	1 m/s	400 bar (40 Mpa)
XH-ECOPUR™				1,2 m/s	
XS-ECOPUR™					
SKF ECOFLON 2	SKF ECORUBBER-1	SKF ECOTAL SKF ECOMID <sup>2</sup>	-30 °C...+100 °C	1,5 m/s	400 bar (40 Mpa)
SKF ECOFLON 3					
SKF ECOFLON 4	SKF ECORUBBER-2	SKF ECOPAЕК	-20 °C...+200 °C		

The stated operation conditions represent general indications. It is recommended not to use all maximum values simultaneously. Surface speed limits apply only to the presence of adequate lubrication film.

<sup>1</sup> Pressure ratings depend on the size of the extrusion gap.

<sup>2</sup> ≤ Ø260mm: SKF ECOTAL ; > Ø260mm: SKF ECOMID

### Ordering example

K23-F, D=100mm, d=80mm, L=25mm, SKF ECOFLON 3 / SKF ECORUBBER-1 / SKF ECOTAL

**Piston Seal K23-F 100 x 80 x 25 SKF ECOFLON 3 / SKF ECORUBBER-1 / SKF ECOTAL**  
 Profile D x d x L Sealing material / Energizer / Backup ring