

### Piston seals

### Seal housing

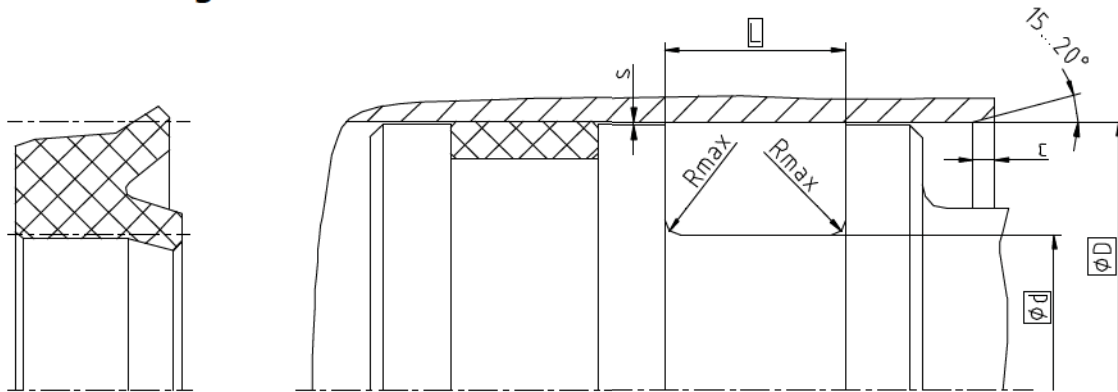

Surface roughness	Rtmax	Ra
Sliding Surface	≤ 2,5 µm	0,1...0,5 µm
Bottom of groove	≤ 6,3 µm	≤ 1,6 µm
Groove face	≤ 15 µm	≤ 3 µm

Ordering dimensions...□

Bearing area: 50...95% and a cutting depth of 0,5xRz based on Cref = 0%

### Standard dimensions

ØD H9	Ød h10	L +0,2	Rmax	c	max. radial extrusion gap s*		
					20 bar	100 bar	160 bar
≥ 13 ... ≤ 25	D - 8	6,0	0,4	3,5	0,23	0,16	0,14
> 25 ... ≤ 50	D - 10	7,0	0,4	4,0	0,26	0,19	0,17
> 50 ... ≤ 75	D - 12	8,0	0,4	4,5	0,29	0,22	0,20
> 75 ... ≤ 150	D - 15	10,0	0,4	5,0	0,32	0,24	0,22
> 150 ... ≤ 300	D - 20	12,0	0,4	6,0	0,35	0,27	0,25
> 300 ... ≤ 500	D - 25	18,0	0,4	8,5	0,39	0,30	0,29
> 500 ... ≤ 750	D - 30	20,0	0,4	10,0	0,40	0,34	0,32
> 750	D - 40	26,0	0,4	13,0	0,40	0,34	0,32

\* Extrusion gap applies to a temperature of 70 °C, higher temperatures require lower values.

### Operating parameters

Sealing material	Temperature	max. speed	max. pressure <sup>1</sup>
<b>SKF ECORUBBER-1</b>	<b>-30 °C...+100 °C</b>	<b>0,5 m/s</b>	<b>160 bar (16 MPa)</b>
SKF ECORUBBER-2	-20 °C...+200 °C		
SKF ECORUBBER-3	-50 °C...+150 °C		
SKF ECORUBBER-H	-25 °C...+150 °C		
SKF ECOSIL	-60 °C...+200 °C	-	-
SKF ECOFLAS	-10 °C...+200 °C	0,5 m/s	160 bar (16 MPa)

The stated operation conditions represent general indications. It is recommended not to use all maximum values simultaneously. Surface speed limits apply only to the presence of adequate lubrication film.

<sup>1</sup> Pressure ratings depend on the size of the extrusion gap.

### Ordering example

K01-RE, D=100mm, d=85mm, L=10mm, SKF ECORUBBER-1

**Piston Seal K01-RE**  
Profile

**100 x 85 x 10**  
D x d x L

**SKF ECORUBBER-1**  
Sealing material