





RC-250, 300, 400, 500

HORIZONTAL SETTING WITH ROTARY JOINT

RC-Series rotary tables are designed for integration into a specialized machine tool or transfer line. RC-Series tables feature extra rigid castings for heavy duty applications. Standard equipment for RC-Series tables includes a built-in (8) port hydraulic/pneumatic rotary joint unit and (1) coolant port.



RC-300

Table Model		RC-250	RC-300	RC-400	RC-500
Table diameter	mm	250	320	400	500
Table height	mm	230	250	260	270
Servo motor (Fanuc)*		Alpha 8i	Alpha 12i	Alpha 22i	Alpha 22i
Maximum motor speed	rpm	4,000	4,000	3,000	3,000
Speed reduction ratio		1/36	1/45	1/45	1/90
Maximum table speed	rpm	111.1	88.8	66.7	33.3
Inertia converted into motor shaft	$\times 10^{-3}\text{kg}\cdot\text{m}^2$.68	1.36	2.30	3.60
Clamp system**		Hydraulic			
Clamp torque @500psi	Nm (ft. lbs.)	540 (398)	900 (663)	1,900 (1,400)	3,400 (2,506)
Indexing accuracy	arc sec.	±12.5			
Net Weight	kg (lbs.)	130 (286)	200 (440)	290 (638)	390 (858)
Allowable wheel torque	Nm (ft. lbs.)	660 (486)	966 (712)	1,535 (1,131)	2,815 (2,075)
Allowable work inertia	$\text{kg}\cdot\text{m}^2$	2.36	7.1	10.9	33.5
Allowable work weight	 kg (lbs)	300 (660)	450 (990)	650 (1,430)	650 (1,430)
Allowable eccentric load	 Nm (ft. lbs.)	350 (258)	700 (516)	960 (708)	960 (708)
Allowable load when table clamped	 N (lbf)	19,600 (4,390)	29,400 (6,586)	39,200 (8,781)	39,200 (8,781)
	 Nm (ft. lbs.)	540 (398)	900 (663)	1,900 (1,400)	3,400 (2,506)
	 Nm (ft. lbs.)	931 (686)	2,000 (1,474)	4,000 (2,948)	4,000 (2,948)

* Other motors & RPM available
 ** Booster optional
 Specifications subject to change without notice

Dimensions

Drawings not to scale • Dimensions = mm

RC-250

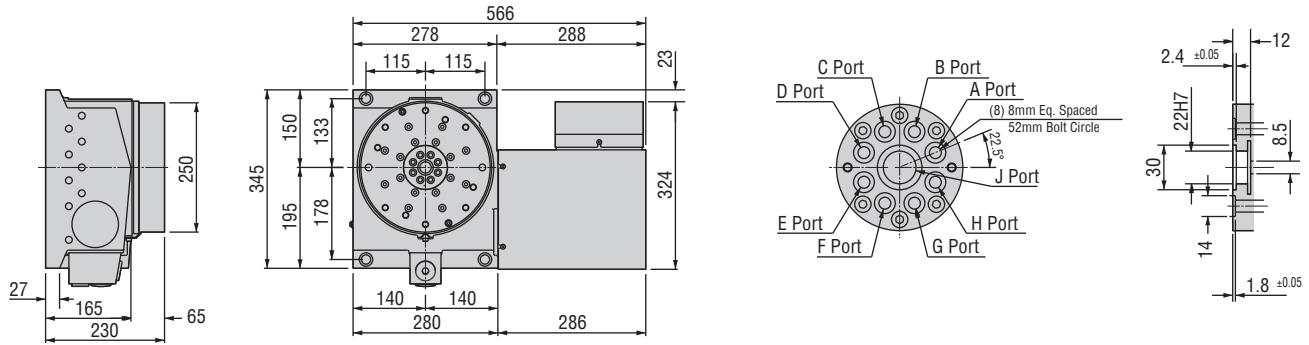

RC-300

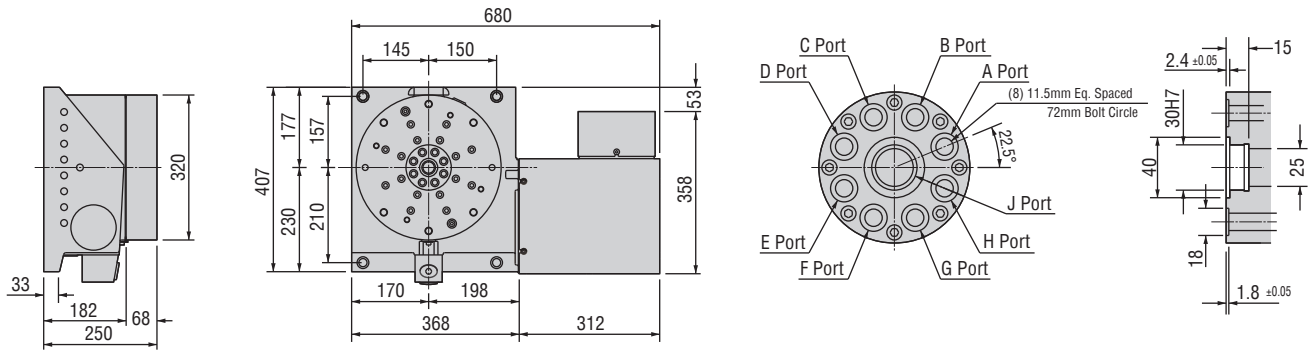

RC-400

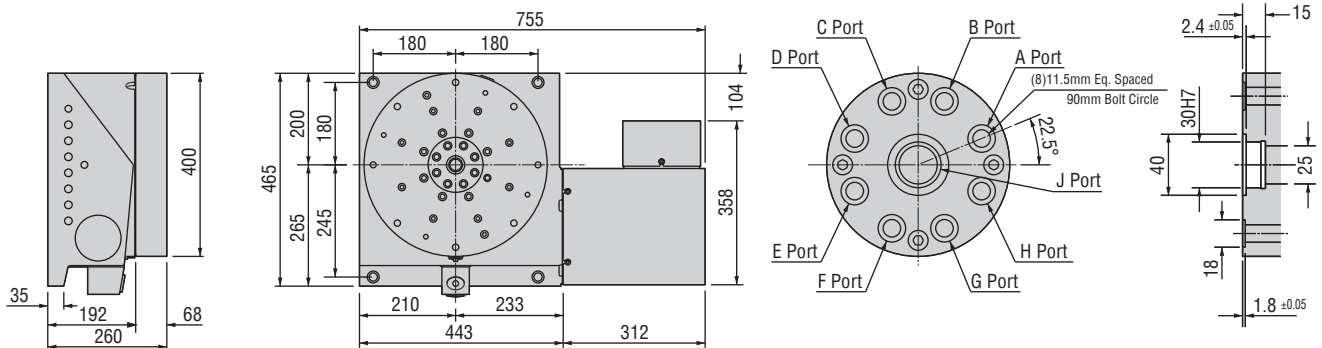

RC-500

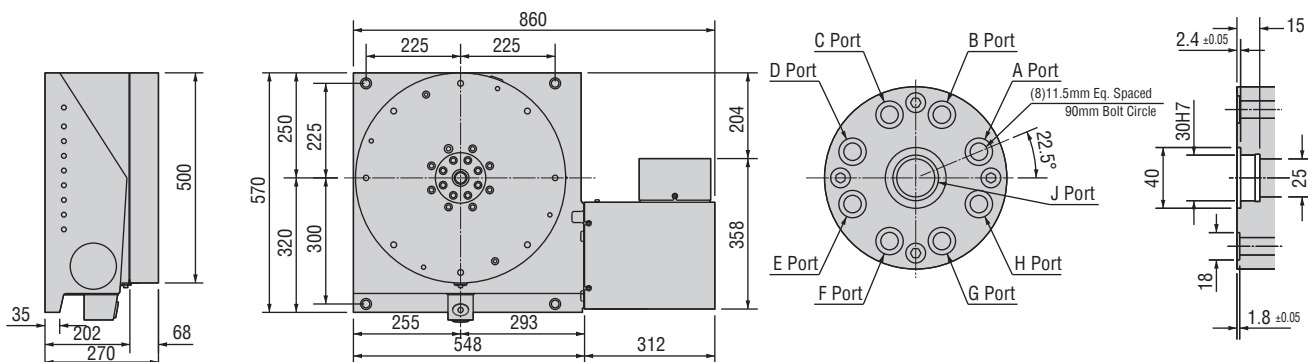

The dimensions above are for tables with a FANUC servo motor. Other motors available (dimensions may increase).