

# **iiipa**®

INTERNATIONAL

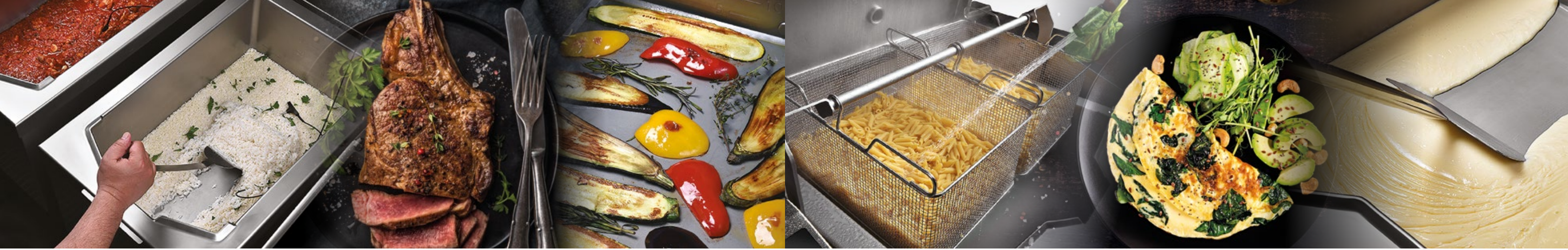



## Multifunctional technology for easy cooking, frying, grilling...

### Savings



ENERGY SAVINGS



SPACE SAVING



WATER SAVINGS



RESOURCE SAVING



TIME SAVING

### Diversity



VARIABILITY OF HEAT TREATMENTS



WIDE MODEL RANGE



MULTIPLE LANGUAGE VERSIONS



CREATION AND MODIFICATION OF OWN RECIPES



90% RECYCLABLE

### Flexibility



REPLACES TRADITIONAL TECHNOLOGIES



PARALLEL PREPARATION OF MULTIPLE DISHES ON ONE DEVICE



EASY MAINTENANCE



EASY TO USE INTUITIVE 12" DISPLAY



ENVIRONMENTALLY FRIENDLY

### CONTROL PANEL



- digital support
- recipe management
- always the same result

- 12" colour touch screen
- Fast response
- Chemically hardened
- Multiple language versions

- Preset technological procedures
- Display of information messages
- HACCP Display directly on the Display
- Display of the food treatment process directly on the Display



- 12" touch screen
- Liquid level scale
- Electromechanical pan tilting
- Automatic water filling
- Water drain from the bottom of the pan

- Shower with automatic winding

- Multi-point probe

- Excess steam extraction

- 230 V/16 A socket + USB socket

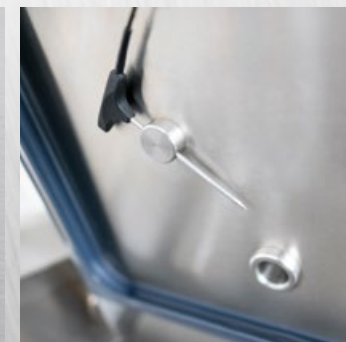



## iipā DESIGN

- Central connection of water, drain and electricity from the wall or floor.
- Special bottom with double-sided weld.
- The control panel can be positioned on the left or right.
- 12" touch screen.
- Excess steam exhaust through the chimney in the centre of the lid.
- Hygienic multipoint probe holder.
- Designed for placement on building plinth or CN plinth.
- Liquid quantity gauge.
- Electrical socket and USB input located in the leg.
- Material AISI 304.
- Material of the pan AISI 316.

## iipā STANDARD

- Automatic basket lifting, driven by a separate motor, with the possibility of use with the lid closed.
- Sensor for detecting the hanging of the basket arm.
- Safety lid operation process to prevent accidents.
- JPX 17 – All-round heating with thick film heating elements.
- Insulated bath, ensures minimum electricity consumption.
- Automatic water filling system.
- Two-speed electromechanical bath tilting.
- Multi-point probe.
- Integrated shower with Automatic winding.
- HACCP – Hazard Analysis and Critical control point system.
- Internet connection.
- Service access from the front and top of the unit.
- Unique depressurisation system without direct water consumption.

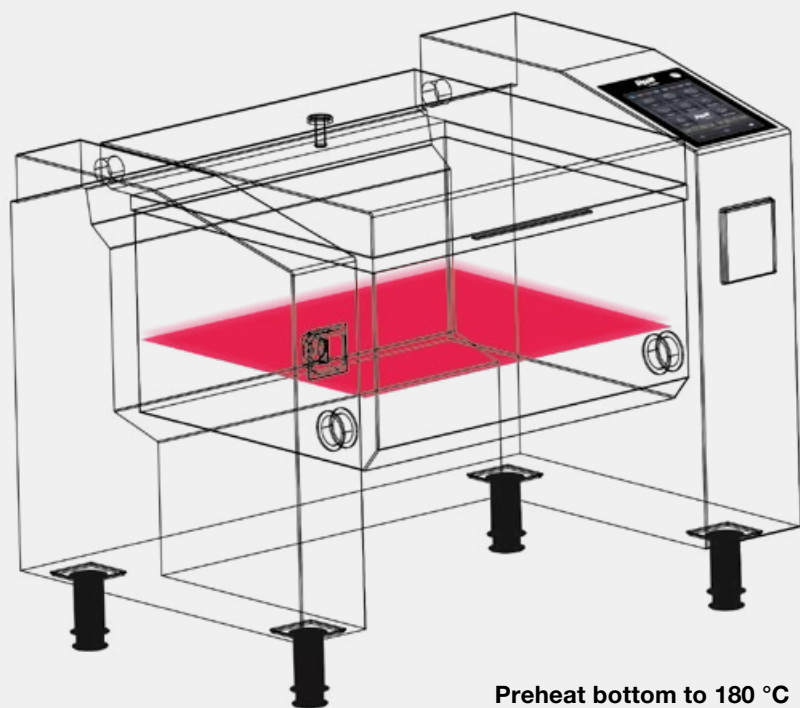

### JPX 17 - Thick film heating elements

- Ensures even temperature distribution over the entire surface

Maximum performance with maximum precision

### Special pan bottom

- Scratch-resistant
- Ensures precise temperature control
- No burning  
No overcooking  
Easy cleaning



Preheat bottom to 180 °C  
from operating temperature  
in 3 minutes



Temperature range  
30 - 250 °C





## **ipd** ACCESSORIES



### **BATTERY-POWERED LIFTING TROLLEY** ▾

- Mobile use without permanent connection to the electricity supply
- Easy handling during emptying of the pan
- Safety handle
- Safety locking of the power cable
- Easy removal of GN
- Hygienic rollers with locking
- Dimensions 600 × 780 × 990 mm
- Weight 55 kg
- Load capacity 40 kg



### **OIL FILTER TROLLEY** ▾

- Safe oil filtering
- Removable and washable filter
- Safety lock for power cord
- Safety handle
- Hygienic rollers with locking rotatable filling arm
- Dimensions 625 × 625 × 1 150 mm
- Weight 65 kg
- Capacity 50 l



### **TRANSPORT TROLLEY FOR COOKING AND FRYING BASKETS** ▾

- Easy and safe storage, transport and dripping of containers
- Removable drip tray for easy maintenance
- Hygienic rollers with locking mechanism
- Safe handling
- Dimensions 600 × 860 × 1 600 mm
- Weight 25 kg
- 6 basket capacity

### **OTHER ACCESSORIES** ▾

- Cooking basket
- Frying basket
- Small baskets for à la carte dishes
- Spatula with handle
- Spatula without handle
- Arm for automatic basket lifting
- Grid 1/1 for LT-cooking
- Drain strainer
- Spaetzle sieve

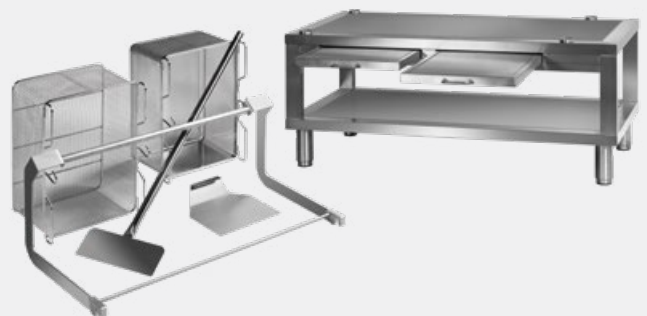



INTERNATIONAL

**JIPA International s.r.o.**  
Formanská 6, 149 00 Praha-Újezd  
Czech Republic

[info@jipainternational.cz](mailto:info@jipainternational.cz)  
[www.jipainternational.cz](http://www.jipainternational.cz)

